

PRIME TIME
Manufacturing



Your Journey Begins Here



27RKS



For both the first-time buyer and seasoned camping veteran, the value-conscious Avenger often represents a customer's first experience with a recreational vehicle from Prime Time Manufacturing.

Since first impressions are critical—and last a lifetime—we've insisted that Avenger combine comfort, convenience, and style with the industry's highest standard of quality and construction. By providing a GREAT ownership experience, Avenger is Prime Time's way of welcoming you to our family.

We hope that your future journeys will always include a Prime Time RV.



24BHS

26RDS

To guarantee that Avenger provides true customer satisfaction, our engineers carefully examined every component, every small detail, and every process that went into Avenger's creation.

It was important to offer industry-leading beauty, so shaker-style cabinet doors were paired with premium fabrics, flooring, and countertops for a luxurious appearance.

"Best In Class" features and design elements are utilized to fully maximize customer enjoyment. Innovative EVERLAST® construction and demanding standards for testing were developed to ensure long-term quality and durability.

If "Your Journey Begins Here," Avenger is sure to please.



32RBS



32RBS

AVENGER FLOORPLANS & SPECIFICATIONS



SPECIFICATIONS	26BH	31RKD	32BIT	32DEN	32QBI	32RBS	35MBS	35RES
LENGTH	28' 11"	36' 6"	37' 8"	37' 8"	37' 11"	38' 10"	39' 0"	39' 0"
HEIGHT	10' 7"	11' 4"	11' 4"	11' 4"	11' 4"	11' 6"	11' 3"	11' 3"
HITCH WEIGHT	580 lb.	928 lb.	871 lb.	858 lb.	1,000 lb.	911 lb.	1,076 lb.	1,388 lb.
UNLOADED VEHICLE WEIGHT (UVW)	4,850 lb.	8,159 lb.	8,393 lb.	7,989 lb.	9,029 lb.	8,651 lb.	9,249 lb.	9,206 lb.
CARGO CARRYING CAPACITY (CCC)	2,692 lb.	3,169 lb.	2,840 lb.	3,069 lb.	2,371 lb.	2,460 lb.	1,989 lb.	2,382 lb.

UVW (Unloaded Vehicle Weight)* is the typical weight of the unit as manufactured at the factory. It includes all weight at the unit's axle(s) and tongue or pin and LP Gas. The UVW does not include cargo, fresh potable water, additional optional equipment or dealer installed accessories.

*Estimated Average based on standard build optional equipment.

CCC (Cargo Carrying Capacity)** is the amount of weight available for fresh potable water, cargo, additional optional equipment and accessories. CCC is equal to GVWR minus UVW. Available CCC should accommodate fresh potable water (8.3 lbs per gallon). Before filling the fresh water tank, empty the black and gray tanks to provide for more cargo capacity. ** Estimated average based on standard build optional equipment. See back page for additional specification definitions.



SPECIFICATIONS	20RD	21RB	21RBS	24BHS	24RLS	26BB	26BBS	26BK	26DBS	26RDS	27DBS	27RBS	27RKS	28REI	29BHS	29QBS	29RBS	26DBS LE
LENGTH	24' 11"	26' 9"	27' 7"	28' 2"	29' 4"	28' 11"	30' 5"	28' 11"	TBD	31' 5"	32' 11.5"	32' 11"	32' 11"	33' 9"	TBD	TBD	33' 5"	TBD
HEIGHT	10' 3"	10' 3"	10' 8"	10' 8"	10' 8"	10' 3"	10' 8"	10' 3"	TBD	10' 3"	10' 8"	10' 8"	10' 8"	11' 4"	TBD	TBD	10' 8"	TBD
HITCH WEIGHT	510 lb.	587 lb.	790 lb.	TBD lb.	581 lb.	552 lb.	658 lb.	474 lb.	TBD lb.	700 lb.	721 lb.	765 lb.	681 lb.	764 lb.	TBD lb.	TBD lb.	821 lb.	TBD lb.
UNLOADED VEHICLE WEIGHT (UVW)	4,256 lb.	4,499 lb.	5,294 lb.	5,416 lb.	5,373 lb.	4,680 lb.	5,626 lb.	4,680 lb.	TBD lb.	6,363 lb.	6,652 lb.	6,663 lb.	6,586 lb.	7,136 lb.	TBD lb.	TBD lb.	6,506 lb.	TBD lb.
CARGO CARRYING CAPACITY (CCC)	3,326 lb.	3,050 lb.	2,496 lb.	2,337 lb.	2,208 lb.	2,834 lb.	2,032 lb.	2,834 lb.	TBD lb.	1,337 lb.	2,869 lb.	2,902 lb.	2,895 lb.	3,828 lb.	TBD lb.	TBD lb.	3,115 lb.	TBD lb.

AVENGER STANDARDS & OPTIONS

AVENGER ADVANTAGE PACKAGE*

- Exclusive EVERLAST® Construction:
 - 2" Wall Construction on 16" Centers
 - Cross-Banded Construction
 - 5/8" Seamless Floor Decking up to 24' w/25-year Warranty
 - 5" LVL Headers Above Slideouts
- Gas/Electric DSI Water Heater w/Quick Recovery
- Dexter E-Z Lube Axles
- Exterior Hot/Cold Shower
- Fully Enclosed Underbelly
- LED Lit Power Awning
- Solar Prep
- Backup Camera Prep
- Electric Stabilizer Jacks
- Electric Tongue Jack
- Extra Large Grab Handle
- LED Interior Lighting
- Large Double Door Refrigerator
- Restaurant Style Kitchen Faucet
- LED Lit Kitchen Backsplash
- Flush Mount Glass Top Range Cover
- Ducted A/C
- Bluetooth Entertainment System
- "Solid Stance" Fold Down Steps

CONSTRUCTION

- Exclusive EVERLAST® Construction
- Powder Coated I-Beam Frame
- Full Length Outriggers on Frame
- 8' Exterior Width
- Aluminum Exterior Skin
- R-7 Insulation Throughout
- 2x3 Floor Joists on 16" Centers

- 5" Snow Load Roof Rafters on 16" Centers
- Walk-On Roof w/ 3/8" Roof Decking
- One-Piece TPO Roof
- PEX Plumbing System
- Upgraded Oetiker Water Line Fittings
- Fully Enclosed Underbelly
- Premium Gutter Rails Above all Slides

BEDROOM

- Quilted Residential Bed Spread
- Bedroom TV Cable Connection
- Dual Shirt Closets
- Massive Under-Bed Storage
- Extra Large Overhead Cabinets Above Bed
- Bedside USB Port
- Bedside 110V Power Outlet on each side

INTERIOR FEATURES

- Oversized MAX Slide (N/A 26BH)
- Ducted A/C
- Seamless Carefree Congoleum Flooring
- Massive 87" U-Shape Dinette on MAX Slide Models
- Fully Vented Windows in MAX Slide
- Pleated Shades in Living and Dining Room (N/A 26BH)
- Predrilled and Screwed Cabinetry
- Extended Ball Bearing Drawer Glides
- Jackknife Sofa w/ LED Cupholders and USB Ports (N/A 26BH)
- Residential Grade Carpet in Select Areas
- 82" Interior Ceiling Height
- LED Interior Lighting
- LED TV
- USB Ports in bunks

EXTERIOR FEATURES

- Aerodynamic Front Radius Profile
- "Solid Step" Fold Down Steps
- Doggy-D-Ring
- Bottle Opener
- Extended Drip Spouts
- Black Framed Radius Windows
- DOT Approved Safety Glass Windows
- Fully Vented Windows Throughout
- Dual LP Bottles
- City Water Fill
- Gravity Fresh Tank Fill
- Diamond Plate Rock Guard
- Exterior Shower
- Radial Tires
- Marine Grade Outdoor Speakers
- Radius Entrance Door w/Window
- Bumper w/Sewer Hose Storage and End Caps
- Extra-Large Entry Door Grab Handle
- Outdoor Kitchen (31RKD, 32BIT, 32QBI, 32RBS)
- Solar Prep
- Black Tank Flush
- Exterior TV Bracket
- LED Lit Power Awning
- Backup Camera Prep
- Electric Stabilizer Jacks
- Electric Tongue Jacks
- Spare Tire

APPLIANCES AND EQUIPMENT

- Bluetooth Entertainment System
- Exterior TV Coax Connection
- Cable TV Hook-Up w/RG6 Coax
- Digital TV Antenna w/Signal Booster

- 13,500 BTU Air Conditioner
- 3 Burner Range w/High Output Front Burner
- Large Double Door Refrigerator
- Large 17" Oven
- Range Hood w/Light And Exhaust Fan
- Gas/Electric DSI Water Heater w/ Quick Recovery
- Water Heater Bypass
- 30K BTU Furnace (N/A 26BH - 25K BTU)
- In Floor Ducted Heat
- Auto Ignition Furnace w/Wall Thermostat
- Systems Monitor Panel
- 12V Electrical System w/55 AMP Power Converter
- 110V GFCI Protected
- 12V High Capacity Water Pump
- 30 AMP Power

KITCHEN

- Pot and Pan Drawer Under Stove (Where Available)
- Pot and Pan Drawer Under Refrigerator (Where Available)
- Deep Basin Sink
- Restaurant Style Kitchen Faucet
- LED Lit Kitchen Backsplash
- Flush Mount Glass Top Range Cover

BATHROOM

- Tub Surround
- Shower Curtain w/Curved Track
- Glass Neo-Angle Shower (Select Models)
- 12V Power Vent Fan
- Medicine Cabinet w/Mirror
- Skylight Over Tub/Shower

SAFETY EQUIPMENT / OWNER PROTECTION

- CO Detector
- LP Detector
- Fire Extinguisher
- Leak-Guard Assurance Process
- Smoke Alarm

THERMAL PACKAGE PLUS

- Enclosed Underbelly
- Heated Holding Tanks
- Extended Seasonal Enjoyment

OPTIONS

- 15K BTU A/C
- Sleep-N-Play (32BIT, 32QBI ONLY - in place of Dinette in Bunkroom)
- Free Standing Dinette w/4 Chairs (Mandatory 31RKD; N/A on 26BH, 32DEN, and 35RES)
- 50 AMP Service, Wired and Framed for Second A/C (N/A 26BH)

TANK CAPACITY

- FRESH WATER: 48 Gallons
- GREY WATER: 30 Gallons**
- BLACK WATER: 30 Gallons**

*Mandatory

**Some models vary. See website for additional details.

AVENGER ATI STANDARDS & OPTIONS

AVENGER ATI DVANTAGE PACKAGE*

- Exclusive EVERLAST® Construction
 - 2" Wall Construction on 16" Centers
 - Cross-Banded Construction
 - 5/8" Seamless Floor Decking up to 24' w/25-year Warranty (on floorplans 31' and longer)
 - Fully laminated floor w/aluminum structure (on floorplans under 31')
 - 5" LVL Headers Above Slideouts
- Quick Recovery DSI Water Heater
- Dexter E-Z Lube Axles
- Radial Tires
- Exterior Hot/Cold Shower
- LED Lit Outside Speakers
- LED Lit Power Awning
- Solar Prep
- Backup Camera Prep
- LED Interior Lighting
- Large Double Door Refrigerator
- Large 17" Oven
- Restaurant Style Kitchen Faucet
- LED Lit Kitchen Backsplash
- Fully Enclosed Underbelly
- "Solid Step" Fold Down Steps

CONSTRUCTION

- Exclusive EVERLAST® Construction
- Powder Coated I-Beam Frame
- Full Length Outriggers on Frame
- Aluminum Exterior Skin
- R-7 Insulation Throughout
- 2x3 Floor Joists on 16" Centers (on floorplans 31' and longer)
- Fully laminated floor w/aluminum structure (on floorplans under 31')
- 5" LVL Header Above Slide Outs
- 5" Snow Load Roof Rafters on 16" Centers
- Walk-On Roof w/3/8" Roof Decking
- One-Piece TPO Roof
- PEX Plumbing System
- Upgraded Oetiker Water Line Fittings
- Premium Gutter Rails Above all Slides
- Fully Enclosed Underbelly

BEDROOM

- Quilted Residential Bed Spread
- TV Cable Connection
- Dual Shirt Closets
- Massive Under-Bed Storage
- Bedside 110V Power Outlets (2)
- Extra Large Overhead Cabinets Above Bed
- Bedside USB Port

INTERIOR FEATURES

- Mini Blinds Throughout
- USB Ports in Bunks
- Extended Ball Bearing Drawer Guides
- Predrilled and Screwed Cabinetry
- 50" TV Standard on 27DBS, 27RKS, 27RBS, 28REI, and 29RBS
- 78" Interior Ceiling Height
- LED Interior Lighting
- Seamless Carefree Congoleum Flooring

EXTERIOR FEATURES

- 8' Exterior Width
- Exterior Shower
- 4 Stabilizer Jacks
- Extended Drip Spouts
- Black Framed Radius Windows
- DOT Approved Safety Glass Windows
- Fully Vented Windows Throughout
- Dual LP Bottles
- City Water Fill
- Gravity Fresh Tank Fill
- Diamond Plate Rock Guard
- Radius Entrance Door w/ Window
- Solar Prep
- Outdoor Kitchen (24BHS, 26BK, 26DBS, 27DBS, 27RBS, 29BHS, 29QBS, 29RBS)

- LED Lit Power Awning
- Doggy-D-Ring
- Bottle Opener
- Aerodynamic Front Radius Profile
- "Solid Step" Fold Down Steps
- Spare Tire

APPLIANCES AND EQUIPMENT

- Cable TV Hook-Up w/RG6 Coax
- Digital TV Antenna w/Signal Booster
- Bluetooth Entertainment System
- 13,500 BTU Air Conditioner
- Large 17" Oven
- 3 Burner Range w/High Output Front Burner
- Range Hood w/Light And Exhaust Fan
- Large Double Door Refrigerator
- Quick Recovery DSI Gas Water Heater
- Water Heater Bypass
- 25K BTU Furnace (N/A 29RBS, 30K BTU)
- EZ Winterization Hookup
- Auto Ignition Furnace w/Wall Thermostat
- Systems Monitor Panel
- 110V GFCI Protected
- 12V High Capacity Water Pump
- 30 AMP Power
- 12V Electrical System w/55 AMP Power Converter

KITCHEN

- Deep Basin Sink
- Restaurant Style Kitchen Faucet
- LED Lit Kitchen Backsplash

BATHROOM

- Shower Curtain w/ Curved Track
- Medicine Cabinet w/ Mirror

SAFETY EQUIPMENT / OWNER PROTECTION

- CO Detector
- LP Detector
- Fire Extinguisher
- Smoke Alarm
- Leak-Guard Assurance Process

OPTIONS

- Free Standing Dinette & 4 Chairs (Max Slide Models)
- 15K A/C (N/A 20RD, 21RB, 26BB, 26BK)

TANK CAPACITY

- FRESH WATER: 48 Gallons
- GREY WATER: 30 Gallons**
- BLACK WATER: 30 Gallons**

*Mandatory **Some models vary. See website for additional details.

HIGH-IMPACT FEATURES



ENCLOSED UNDERBELLY



ELECTRIC STABILIZER JACKS (N/A ATI)



ELECTRIC TONGUE JACK (N/A ATI)



LED LIT POWER AWNING



BACK UP CAMERA PREP



SOLAR PREP



BLACK TANK FLUSH (N/A ATI)



BLUE LED LIT OUTDOOR SPEAKERS



OUTSIDE SHOWER

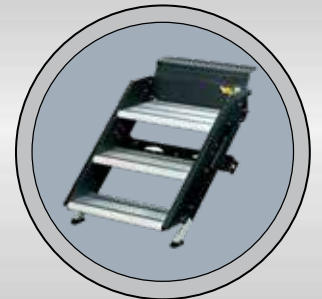

"SOLID STANCE" FOLD-DOWN STEPS



DOGGY D-RING



GLASS TOP STOVE WITH LED LIGHTING

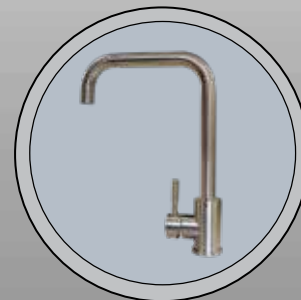

RESTAURANT STYLE KITCHEN FAUCET



LED LIT KITCHEN BACKSPLASH



EXTERIOR BOTTLE OPENER

DSI QUALITY CIRCLE AWARD

Prime Time Manufacturing is proud to be recognized as an industry leader in value, reliability, and overall quality by the Recreational Vehicle Dealers Association. We are committed to "A Higher Standard" in design, construction, testing, and customer service. Check us out — we know you'll be impressed!



Seek-A-Leak Pressure Test



Seal Tech Air Pressure Test



Executive Quality Audits



Web Based Customer Service



65 Point Secondary PDI



Advanced Engineering



Rain Bay



FROG™ the Forest River Owners' Group!

www.primetimerv.com
PO Box 330 • 55470 CR 1 • Elkhart, IN 46515



FREE MEMBERSHIP
to Forest River Owners' Group

www.forestriverfrog.com



CUSTOMER SATISFACTION



www.ForestRiverBuyLocal.com



ADDITIONAL SPECIFICATIONS:

GVWR (Gross Vehicle Weight Rating) - is the maximum permissible weight of the unit when fully loaded. It includes all weights, inclusive of all fluids, cargo, optional equipment and accessories. For safety and product performance do NOT exceed the GVWR.

GAWR (Gross Axle Weight Rating) is the maximum permissible weight, including cargo, fluids, optional equipment and accessories that can be safely supported by a combination of all axles.

Each Forest River RV is weighed at the manufacturing facility prior to shipping. A label identifying the unloaded vehicle weight of the actual unit and the cargo carrying capacity is applied to every Forest River RV prior to leaving our facilities. The load capacity of your unit is designated by weight, not by volume, so you cannot necessarily use all available space when loading your unit.



PRE-DELIVERY INSPECTION FACILITY

20,000 square feet of quality assurance. The bare essentials for a premium product. This state-of-the-art facility gives immediate daily feedback to production for quality assurance in every unit built.

Download the Prime Time Manufacturing mobile app or visit our dynamic online manual to enhance your ownership experience. These interactive options provide incredible ease and insight into use, maintenance and enjoyment of your Prime Time Manufacturing product. From "How-To" videos, pictures and illustrations of various components, systems and features, to fully searchable content and downloadable PDFs for individual component owner's manuals, answers are always just a click away.



View the online manual at <http://www.primetimerv.com/OnlineManual.aspx> or download our FREE app from the App Store or Google Play!

All information contained in this brochure is believed to be accurate at the time of publication. However, during the model year, it may be necessary to make revisions and Forest River, Inc., reserves the right to make all such changes without notice, including prices, colors, materials, equipment and specifications as well as the addition of new models and the discontinuance of models shown in this brochure. Therefore, please consult with your Forest River, Inc., dealer and confirm the existence of any materials, design or specifications that are material to your purchase decision.

©2018 Prime Time Manufacturing, a Division Of Forest River, Inc., a Berkshire Hathaway Company. All Rights Reserved.



Learn More
Scan this barcode using a QR Reader on your smart phone to learn more about Forest River.



A Berkshire Hathaway company.

DEALER