

**DSI**  
Annual RVDA DEALER  
SATISFACTION INDEX  
AWARD WINNER



**RAPTOR**  
TOYHAULERS

 **Keystone RV  
Company**



# RAPTOR



**THANK YOU NORTH AMERICA. ONCE AGAIN, YOU HAVE MADE RAPTOR THE BEST-SELLING TOYHAULER 8 YEARS RUNNING.**



**Thank You! Once again you have made Raptor the best selling Toy Hauler in North America 8 years running!**

Forget what you know about “toy haulers”. The new Raptor is not just for those who haul quads, dirt bikes and motorcycles. Smart design and floorplan innovation enable Raptor to excel at delivering multi-zone living, sophistication and your own personal style. Whether you are a growing family, hobbyist, craftsman, outdoor enthusiast, or full timer there is a Raptor floorplan that will enhance your lifestyle.

**Raptor Red Full Paint Option**





## FIFTH WHEELS

### King-Size Toyhaulers

For those who want everything a toyhauler can offer, our Full Feature Raptors are rugged enough to get you where you want to go but offer all the luxurious amenities like king beds, Corian countertops, and 40" TV's on the inside to make you not want to leave.



..... Pages 4-16



## SE FIFTH WHEELS

### Lighter Weight Toyhaulers

Raptor's SE line up has all of the features that make a Raptor a Raptor, and are lighter weight and value priced. Raptor SE gives you all of the bang for less of the buck. Essentials such as 7,000 axels, 8' Ramp Doors, and sunken showers are standard in every SE fifth wheel.



..... Pages 17-20



## TRAVEL TRAILERS

### Big Things in Small Packages

The all new Travel Trailer line up from Raptor gives you everything you need in a toy hauler in a lightweight low cost package. Measuring the same 102" wide as the fifth wheel Raptors, and featuring 1/2 ton towability gives these travel trailers the best of both worlds.



..... Pages 21-24

# RAPTOR

## FIFTH WHEELS

RAPTOR FIFTH WHEELS



THE PERFECT PLACE TO WIND DOWN AFTER A LONG DAY OF ADVENTURE



EVERYTHING YOU'LL NEED IN THE GARAGE AREA.  
A 12' GARAGE WITH A TWIN LOFT ABOVE AND HALF BATH.





**PLAY AS HARD AS YOU CAN  
AND RELAX AS MUCH AS YOU  
WANT... THE REDESIGNED 395  
CAN HANDLE IT ALL. FROM THE  
MOUNTAINS TO THE RACE TRACK  
AND EVERYWHERE IN BETWEEN.  
WHETHER IT BE FAMILY OR  
FRIENDS, THE 395 PROVIDES  
PLENTY OF ROOM FOR EVERYONE.**

**FIFTH WHEEL**

**INTERIOR**



RAPTOR FIFTH WHEELS

**395LEV FIFTH WHEEL SHOWN IN ECLIPSE DECOR**

**WWW.KEYSTONERV.COM/RAPTOR 5**

# RAPTOR

## FIFTH WHEELS

RAPTOR FIFTH WHEELS



RECESSED SHOWER

RECESSED SHOWER ALLOWS FOR MAXIMUM HEIGHT OF 6' 11"



APPLIANCE CENTER (381, 395)



KITCHEN PANTRY 381, 384, 4014)





**CANT WAIT TO HIT THE TRAILS,  
DOMINATE THE DESERT OR JUST  
HANG OUT IN THE BACK COUNTRY.  
RAPTOR IS READY FOR YOUR KIND  
OF ACTION. ITS TIME TO GO!**

## FIFTH WHEEL **INTERIOR**



**LIKE RAPTOR, SONY IS A LEADER IN  
THEIR FIELD. THAT IS WHY RAPTOR  
ONLY USES SONY COMPONENTS IN THE  
ENTERTAINMENT SYSTEM. QUALITY AND  
VALUE FROM SONY, ONLY IN A RAPTOR.**

RAPTOR FIFTH WHEELS

# RAPTOR

## KING BED SUITE

**NOW FEATURED ON THESE 7 FLOORPLANS!**

**310TS, 332TS, 365LEV, 381LEV, 384LEV, 410LEV AND 4014LEV**

RAPTOR FIFTH WHEELS



**"LED LIGHTS GIVE YOU A SOFT GLOW FOR NIGHT TIME NAVIGATION."**







RAPTOR'S **ALL NEW KING BED SUITE** IS A FIRST IN THE TOY HAULER SEGMENT. WITH A WALK AROUND KING BED, DUAL NIGHT STANDS, LED ACCENT LIGHTING, 32" TV, AND AN ACCENT MIRROR, YOU WILL NEVER WANT TO LEAVE THE COMFORT OF YOUR KING BED SUITE! RAPTOR OFFERS THIS IN NOT JUST ONE OR TWO FLOOR PLANS, BUT SEVEN! ANOTHER TOY HAULER EXCLUSIVE BROUGHT TO YOU BY RAPTOR.

## ***KING BED SUITE***



RAPTOR FIFTH WHEELS

# RAPTOR

RAPTOR FIFTH WHEELS



12 CU. FT. REFRIGERATOR



PULL OUT FAUCET

## INTERIOR FEATURES

SOLID SURFACE SINK  
AND STOVE COVERS



LARGE 40" HDTV



**FRAME INTEGRATED WORRY-FREE D-RINGS KEEP YOUR TOYS FROM SLIDING AROUND IN THE GARAGE**



**DOVETAIL STORAGE IN THE GARAGE IS A MUST-HAVE FOR TOOLS AND SAFETY EQUIPMENT**

# ***GARAGE* FEATURES**

**8' RAMP DOOR MAKES IT EASY TO LOAD AND UNLOAD YOUR TOYS**



**ELECTRIC BUNK BEDS CREATE THE ULTIMATE BUNKHOUSE**



**TURN YOUR GARAGE INTO AN OUTDOOR OASIS WITH THE REAR PATIO SYSTEM (OPTIONAL)**



# RAPTOR CONSTRUCTION AND FEATURES

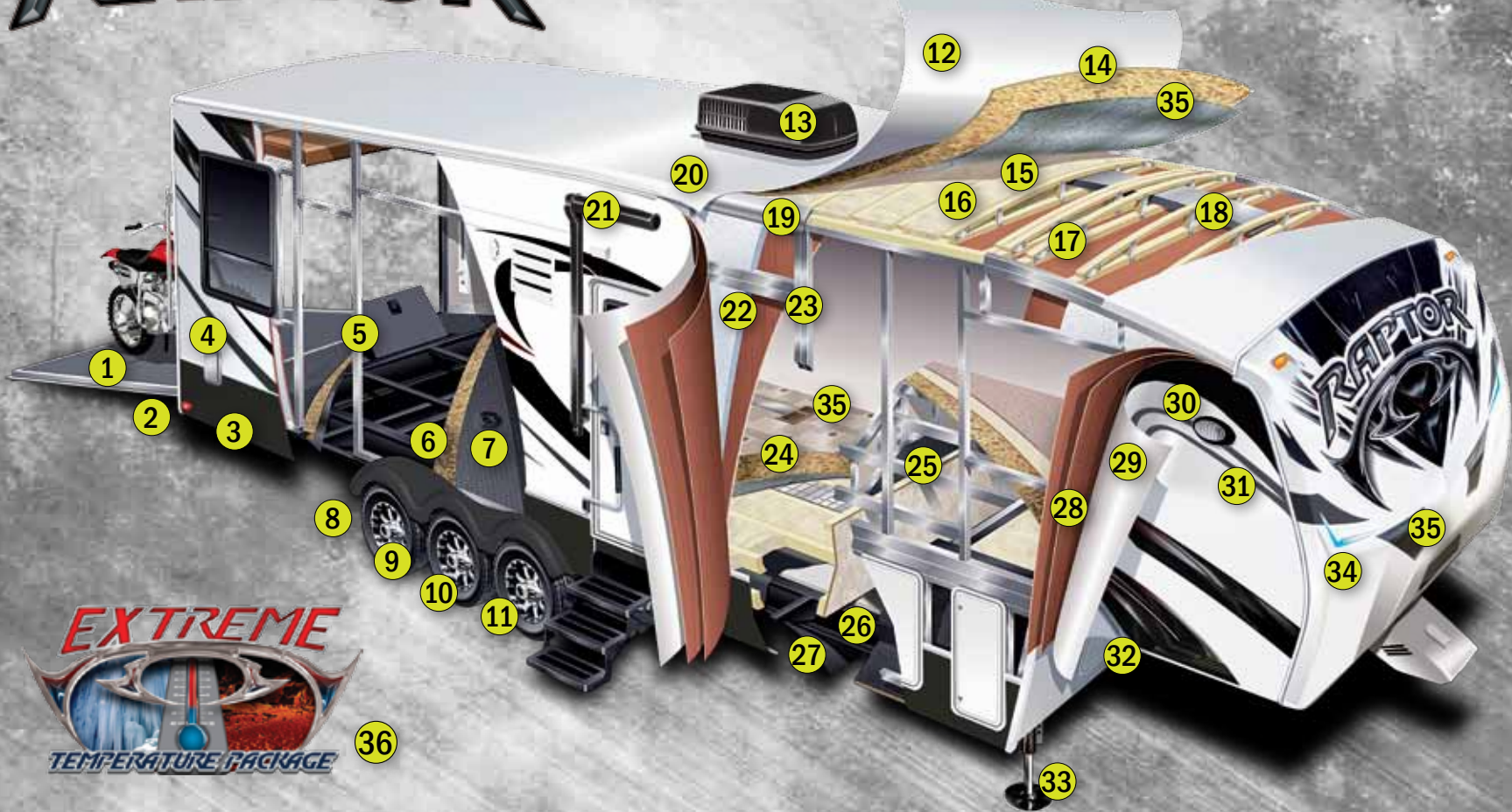

RAPTOR FIFTH WHEELS





- ① 8' Light weight, rear gate 3,000 lb. capacity w/ spring assist
- ② LED brake lights
- ③ Electric rear stabilizer jacks
- ④ Ram air ventilation
- ⑤ In-floor storage bin
- ⑥ 1" garage floor decking
- ⑦ Integrated d-rings
- ⑧ 16" E-rated radial tires
- ⑨ Aluminum wheels
- ⑩ Drum brakes - all wheels
- ⑪ 7,000 lb. axles
- ⑫ One-piece EDPM rubber roof w/ 12 year warranty
- ⑬ 15,000 BTU A/C
- ⑭ 3/8" roof decking
- ⑮ Wired and braced for a 2nd A/C
- ⑯ Rolled fiberglass insulation
- ⑰ 5" wood trusses 16" on center
- ⑱ Aluminum wrapped A/C duct
- ⑲ Aluminum radius roof transition molding
- ⑳ Vented attic
- ㉑ Electric patio awning
- ㉒ High density solid block insulation foam
- ㉓ 2" welded aluminum wall studs
- ㉔ 5/8" Dyna Span seamless floor decking
- ㉕ 3" welded aluminum floor
- ㉖ 10" or 12" I-Beam chassis
- ㉗ Fluted polypropylene enclosed and insulated underbelly
- ㉘ Double layer luan w/ staggered seams
- ㉙ Fully laminated sidewalls
- ㉚ Security light
- ㉛ High-gloss exterior
- ㉜ On board generator (optional)
- ㉝ Optional 6-Point Level Up by Lippert
- ㉞ Front cap designed for improved turning radius
- ㉟ Hitch vision
- ㊱ Extreme temperature package with astro-foil. R Values: ceiling = R38, floor = R31, sidewalls = R9.
- ㊲ Drop frame construction (select models)
- ㊳ Equa-Flex suspension system
- ㊴ Exterior folding ladder
- ㊵ Toy Lock system – a fifteen foot braided retractable cable allowing for peace of mind while you're away from your prized possessions
- ㊶ Convenience Docking Center – hot / cold shower, black tank flush, winterization by-pass, fresh water fill, cable/satellite connections, and battery quick disconnect
- ㊷ Dual 30 gallon fuel station (select models)
- ㊸ L-Shaped lounge with ottoman storage
- ㊹ LED lights in front cap
- ㊺ 1" thick slam latch baggage doors
- ㊻ Single pieces crossmember



# RAPTOR FLOORPLANS

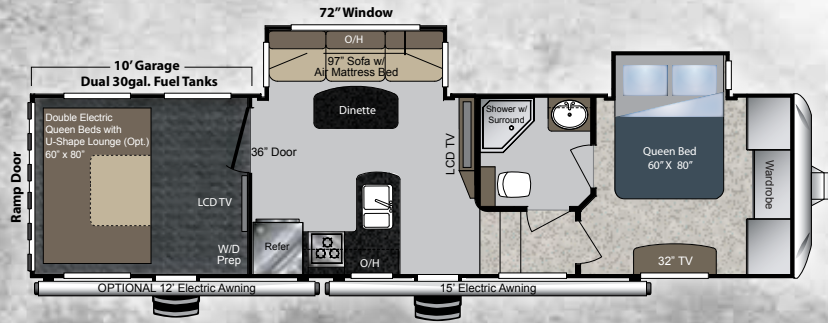

**300MP**

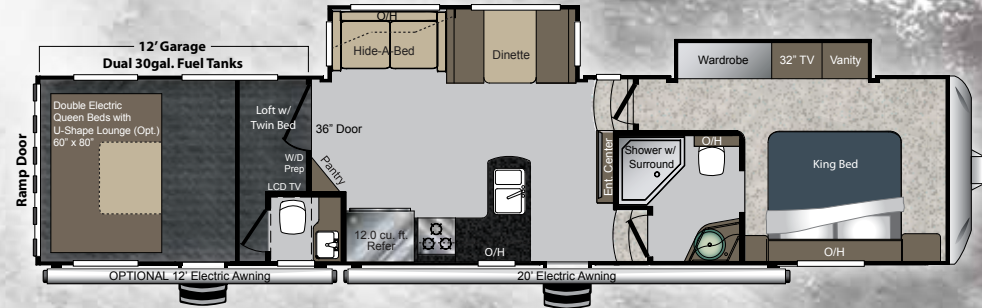

**KING BED SUITE 365LEV**

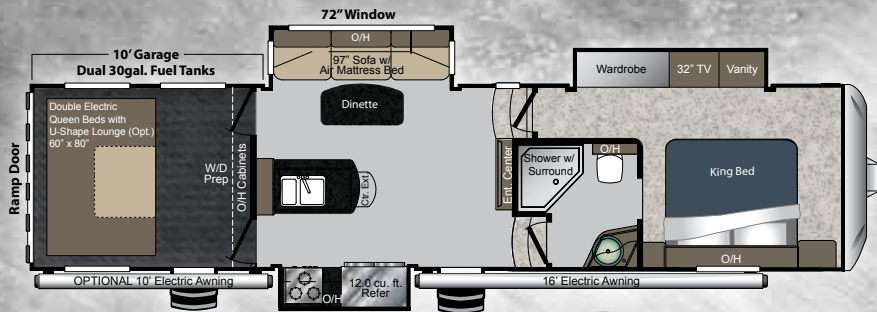

**KING BED SUITE 310TS**

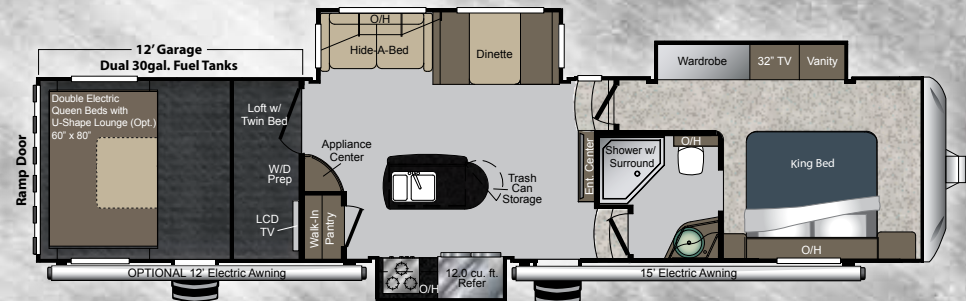

**KING BED SUITE 381LEV**

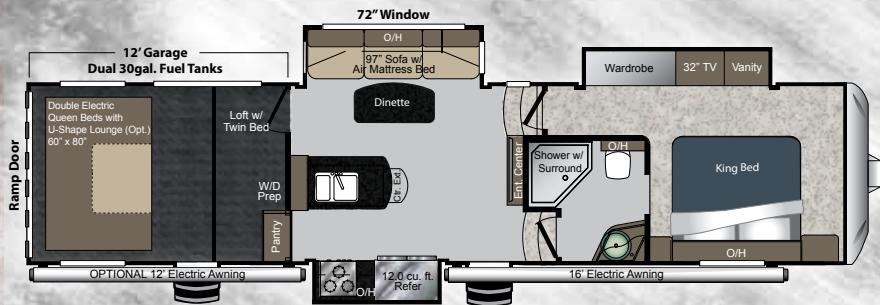

**KING BED SUITE 332TS**

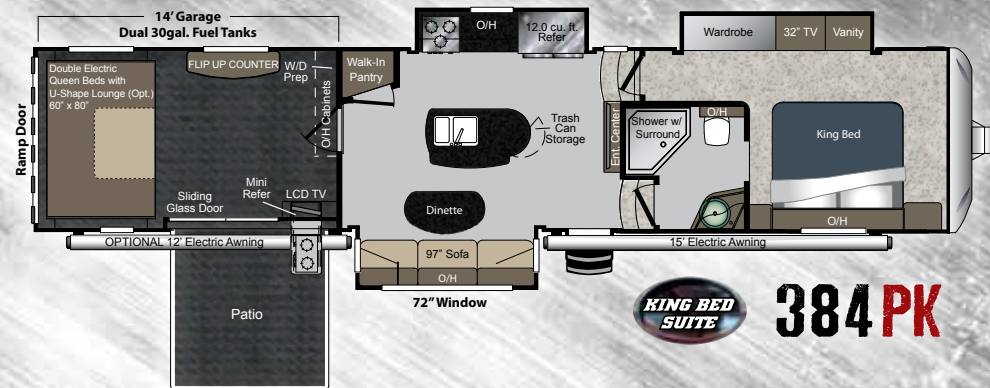

**KING BED SUITE 384PK**

RAPTOR FIFTH WHEELS

# SLIDE ROOM OPTIONS

365LEV & 381LEV ONLY

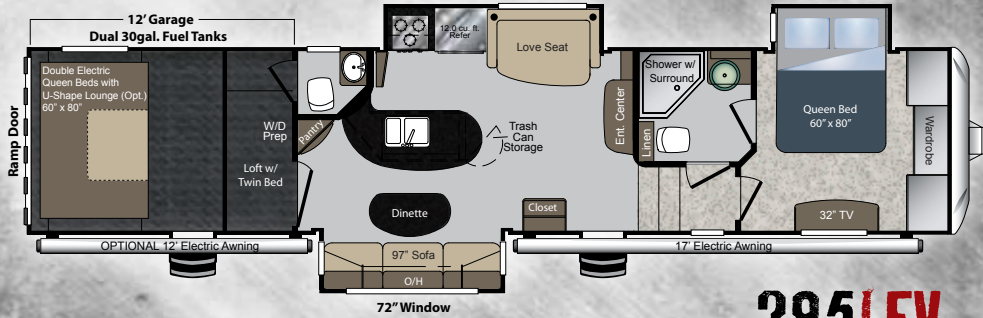
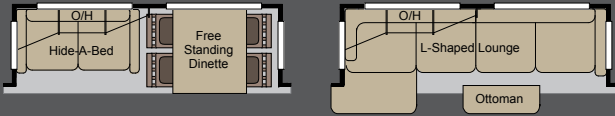

**395LEV**

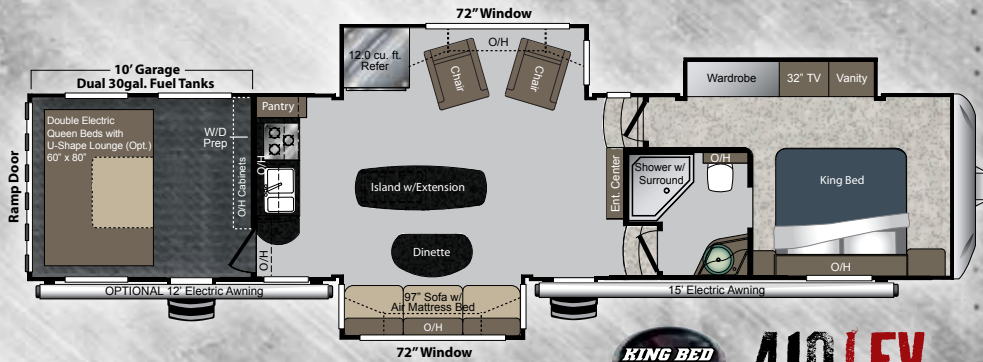

**KING BED SUITE 410LEV**

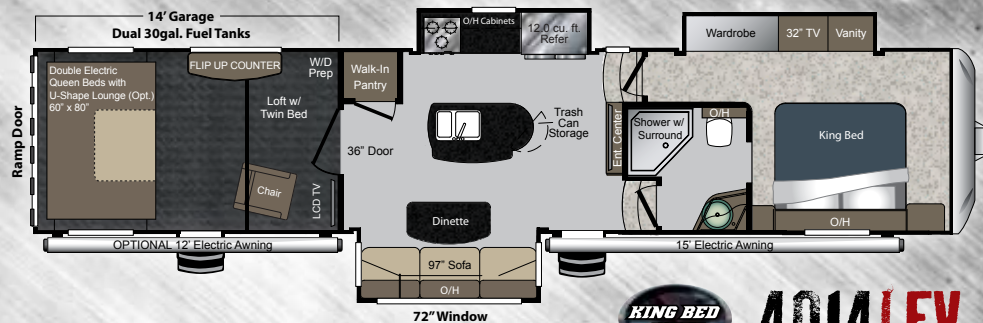

**KING BED SUITE 4014LEV**



INDUSTRY EXCLUSIVE OUTSIDE CAMP KITCHEN



ONE TOUCH 6-POINT LEVEL-UP SYSTEM



RAPTOR GARAGES DOUBLE AS SPACIOUS EXTENDED LIVING AREA

# RAPTOR

## STANDARDS & OPTIONS

# FIFTH WHEELS

THE MOST FULLY EQUIPPED TOYHAULER ON THE MARKET

### INTERIOR

- 12 cu. ft. Refrigerator (8 cu. ft. 300MP)
- 12-Gal. Gas/Electric DSI Water Heater
- 30" Residential Microwave
- 3 Burner Range w/ 22-inch Oven
- Corian Range Cover and Sink Cover
- Upgraded Residential Pull-Out Kitchen Faucet
- Solid Surface Counter Tops
- Large 60/40 Kitchen Sink
- Bar Stools (2)(Select models)
- Hardwood Cabinetry w/ Maple Raised Panel Doors
- 100# Full Extension Ball Bearing Drawer Guides
- Light Feature with LED Accent Lighting and Pendant Lights
- Wooden Crown Molding
- Night Shades
- Side Aisle Master Bath
- Power Vent In The Master Bathroom
- Porcelain Foot Flush Toilet
- Shower Surround
- Skylight in Shower
- Towel Hooks in Bath
- Wooden Residential Interior Door w/ Glass Insert
- Cable / Sat. Prep
- Cargo Carpet
- TV Antenna w/ Booster and Bedroom TV Hook-up
- Raptor Control Panel w/ Fuel Gauge
- Wired & Framed for Second A/C in Bedroom
- Automatic Transfer Switch with Generator Prep
- Battery Quick Disconnect
- 50 Amp Service
- 15,000 BTU Air Conditioner
- 110-Gallon Fresh Water Tank
- Washer Dryer Prep (select models)
- Ducted A/C Into Garage
- Ducted Heat Into Garage (Select models)

### EXTERIOR

- High Gloss Exterior Sidewalls
- Radius Roof w/ One-Piece Rubber Walk-on Roof (EPDM) and a 12 Year Warranty
- Convenience Center (All System Hook-Ups Located In One Area)
- On Board Fuel Station (30 Gallon Capacity) 2nd 30 Gallon Tank
- Exterior Cable / Sat Hook-up
- Rear Spotlights
- 3 Large Outdoor Activity Lights
- One Touch Electric Awning
- Easy Glide Radius Steps
- Large Fold-Away Entry Assist Handle
- Outside Shower / Hot and Cold w/ 25' Coil Hose
- Large Tinted Safety Glass Windows w/ 80% Tint
- Huge Drop Frame Pass-Through Storage
- 1" Slam Latch Baggage Doors
- Exterior Folding Ladder
- Rain Gutters with Extended Drip Spouts
- Ram Air Ventilation System In Garage
- Toy Lock (Keep Your Toys Safe While You Sleep)
- New Upgraded Graphics Package
- Fiberglass Front Cap W/ Max Turn Technology
- Black Tank Flush
- Spare Tire

- Hydraulic Front Jacks and Power Rear Jacks
- Equaflex Suspension
- 7,000 lbs. Ultra Lube Axles
- Premium 8 Lug 16-inch "E" Rated Radial Tires
- Heated And Enclosed Underbelly
- Double Welded Aluminum Construction
- Hydraulic Slide Rooms (select models)
- 5" Pre-Engineered Roof Truss Rafters

### INDUSTRY EXCLUSIVE STEREO SYSTEM

- 40" LCD HDTV
- Sony® Exterior Marine Speakers(2)
- Sony® Interior Speakers(4)
- Sony® Garage Speakers(2)
- Sony® 10-inch Sub Woofer
- Sony® AM/FM/DVD/CD/MP3 Player
- Sony® 500 Watt Amplifier

### OPTIONS

- 2nd A/C (Low Profile 13.5K BTU)
- Euro Style Chair
- Double Electric Beds w/Dual Opposing Rollover Sofas. (only w/Patio Option)
- Rear Door - Screen Wall
- Free Standing Dinette with Four Chairs (Available in Select models)
- Onan 5,500 Watt Gas Generator
- Dual Pane Windows
- Rear Patio System w/ Side Rails and Awning
- 131" L-Shaped Couch with Ottoman (365, 381)
- Full Body Paint (Orange, Red, Blue, Pearl)
- Outside Camp Kitchen
- Level-Up Hydraulic 6-Point Leveling System

### SAFETY PACKAGE

- Carbon Monoxide Detector
- Smoke Detector
- LP Gas Detector
- Fire Extinguisher

RAPTOR FIFTH WHEELS

## SPECIFICATIONS & DECOR OPTIONS

FIFTH WHEELS	300MP	310TS	332TS	365LEV	381LEV	384PK	395LEV	410LEV	4014LEV
SHIPPING WEIGHT	12500	13105	TBD	14455	14365	14860	15020	14925	14560
CARRYING CAPACITY	4000	3395	TBD	3545	3635	3140	2980	3075	3440
HITCH WEIGHT	2860	3000	TBD	3650	3545	3620	3875	3690	3670
EXTERIOR LENGTH	35' 6"	36' 6"	37' 7"	40' 6"	40' 1"	41' 7"	42' 5"	41' 7"	41' 7"
EXT. HEIGHT - A/C TOP	13' 2"	13' 2"	13' 2"	13' 6"	13' 6"	13' 6"	13' 6"	13' 6"	13' 6"
FRESH WATER (GAL.)	110	92	92	110	96	110	110	110	110
WASTE WATER (GAL.)	39	39	39	78	39	39	69	39	39
GRAY WATER (GAL.)	78	78	78	78	76	76	69	69	78
LPG	60	60	60	60	60	60	60	60	60
AWNING	15' & 10'	15' & 10'	16' & 12'	20' & 12'	15' & 12'	15' & 12'	15' & 12'	15' & 12'	15' & 12'

\* Weights reflect a fully equipped coach. See disclaimer on back cover.



TWILIGHT

COGNAC

ECLIPSE



# RAPTOR



## SE FIFTH WHEELS

Pages 17-20

RAPTOR SE FIFTH WHEELS

# RAPTOR

## SE FIFTH WHEELS

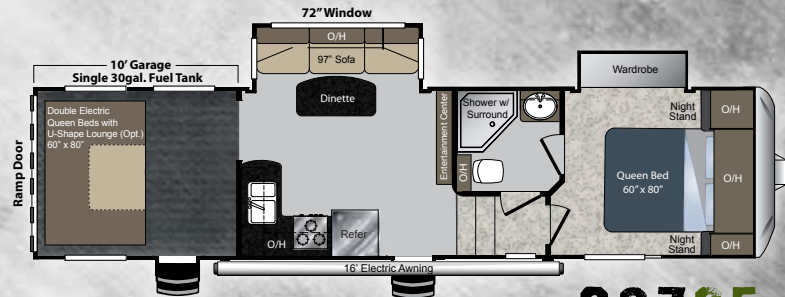

**297SE**

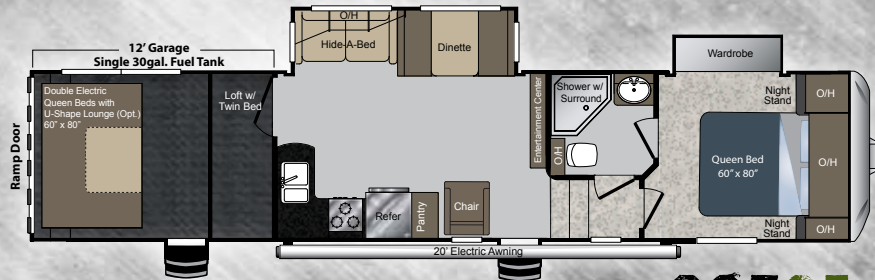

**367SE**

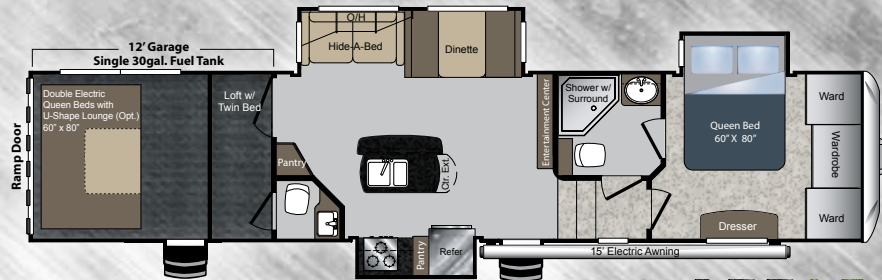

**377SE**



RAPTOR SE FIFTH WHEELS





**RAPTORS SE LINE UP HAS ALL OF THE FEATURES THAT MAKE A RAPTOR A RAPTOR, AND ARE LIGHTER WEIGHT AND VALUE PRICED. RAPTOR SE GIVES YOU ALL OF THE BANG FOR LESS OF THE BUCK. ESSENTIALS SUCH AS 7,000 AXELS, 8 FOOT RAMP DOORS, AND SUNKEN SHOWERS ARE STANDARD IN EVERY SE FIFTH WHEEL.**

## **SE FIFTH WHEELS**



RAPTOR SE FIFTH WHEELS



SPACIOUS BEDROOMS



HALF BATH IN 377SE GARAGE

**377SE SHOWN IN ECLIPSE DECOR**

**WWW.KEYSTONERV-RAPTOR.COM 19**

# RAPTOR

## STANDARDS & OPTIONS

# SE FIFTH WHEELS

ALL THE BANG WITHOUT THE BUCK

### INTERIOR

- Raptor SE Interior
- 8 Cu. Ft. Refrigerator
- 6-Gal. Gas/Electric DSI Water Heater w/ Quick Recovery
- Residential Microwave
- 3 Burner Range w/ 22-inch Oven
- Large 60/40 Kitchen Sink
- High Rise Faucet
- Laminate Counter Tops
- Maple Hardwood Cabinetry w/ 100# Full Extension Ball Bearing Drawer Guides
- Night Shades
- Queen Air Mattress (select models)
- Power Vent In the Master Bathroom
- Porcelain Foot Flush Toilet
- Shower Surround
- Skylight in Shower
- Residential Interior Door w/ Glass Insert (select models)

- Cable / Sat. Prep
- TV Antenna w/ Booster
- Bedroom TV Hook-up
- Raptor Control Panel with Fuel Gauge
- Braced and Wired for Second A/C
- Automatic Transfer Switch with Generator Prep
- Battery Quick Disconnect
- 50 Amp Service
- 15,000 BTU Air Conditioner
- Ducted A/C Into Garage

### EXTERIOR

- Convenience Center (All System Hook-Ups Located In One Area)
- Outside Shower
- Black Tank Flush
- 30 Gallon Fuel Station
- Exterior Cable / Sat Hook-up
- Rear Spotlights

- Outdoor Activity Light
- One Touch Electric Awning
- Easy Glide Radius Steps
- Large Tinted Safety Glass Windows w/ 80% Tint
- Huge Pass-Through Storage
- Detachable Aluminum Roof Ladder
- Rain Gutters with Extended Drip Spouts
- Aluminum "RAM" Air Ventilation System In Garage
- Fiberglass Front Cap
- Spare Tire
- 7,000# Ultra Lube Axles
- Premium 8 Lug 16" "E" Rated Radials
- Heated And Enclosed Underbelly
- Double Welded Aluminum Construction
- Filon Exterior Sidewalls
- Hydraulic Slide Rooms (select models)

- 5" Pre-Engineered Roof Truss Rafters
- One Piece EPDM Rubber Roof (12 year warranty)

### ENTERTAINMENT SYSTEM

- 32" LCD HDTV
- Sony® AM/FM/CD/DVD/MP3 Player
- 4 - Interior Speakers
- 2 - Exterior Marine Speakers

### OPTIONS

- Double Electric Queen Beds with U-Shaped Dinette
- Rear Screen Enclosure
- Onan 5,500 Watt Generator
- Dual Pane Windows
- 131" Sofa In Place of Dinette and Hide-A-Bed Sofa (367 & 377 only)

### SAFETY PACKAGE

- Carbon Monoxide Detector
- Smoke Detector
- LP Gas Detector
- Fire Extinguisher



## SPECIFICATIONS & DECOR OPTIONS

FIFTH WHEELS	297SE	367SE	377SE
SHIPPING WEIGHT	11070	12815	13485
CARRYING CAPACITY	4330	5185	4515
HITCH WEIGHT	2620	3005	3315
EXTERIOR LENGTH	35' 6"	40' 6"	41' 0"
EXT. HEIGHT - A/C TOP	13' 2"	13' 6"	13' 6"
FRESH WATER (GAL.)	86	86	86
WASTE WATER (GAL.)	39	39	69
GRAY WATER (GAL.)	82	78	76
LPG	60	60	60
AWNING	18'	20'	15'

\* Weights reflect a fully equipped coach. See disclaimer on back cover.



TWILIGHT



COGNAC



ECLIPSE

# RAPTOR



## TRAVEL TRAILERS

..... Pages 21-23

# RAPTOR

## TRAVEL TRAILERS

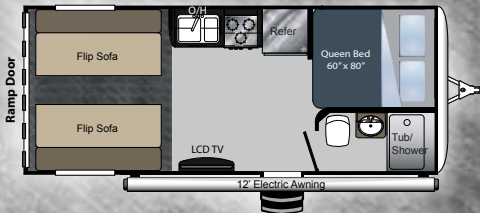

**19FB**

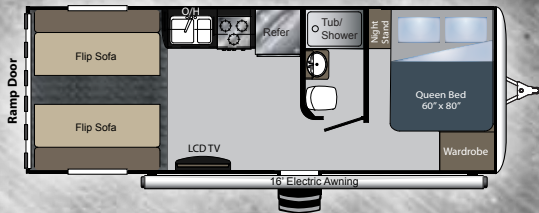

**22FS**

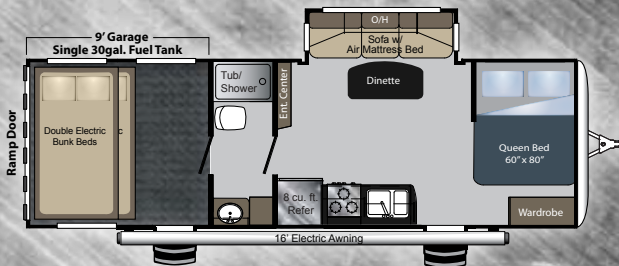

**27FS**

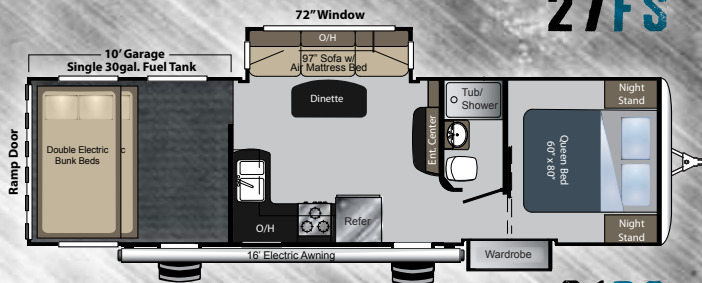

**31DS**



*31DS SHOWN IN TWILIGHT DECOR*



*31DS FRONT BEDROOM SHOWN IN ECLIPSE DECOR*

# RAPTOR

## STANDARDS & OPTIONS

# TRAVEL TRAILERS

ALL THE BANG WITHOUT THE BUCK

### INTERIOR

- 8 Cu. Ft. Refrigerator
- 6-Gal. Gas/Electric DSI Water Heater w/ Quick Recovery
- Residential Microwave
- 3 Burner Range w/ 22-inch Oven
- Large Kitchen Sink
- High Rise Faucet
- Laminate Counter Tops
- Maple Hardwood Cabinetry w/ 100# Full Extension Ball Bearing Drawer Guides
- Night Shades
- Queen Air Mattress (select models)
- Power Vent In the Master Bathroom
- Porcelain Foot Flush Toilet
- Shower Surround
- Skylight in Shower
- Residential Interior Door w/ Glass Insert (select models)

- Cable / Sat. Prep
- TV Antenna w/ Booster
- Bedroom TV Hook-up
- Raptor Control Panel with Fuel Gauge
- Automatic Transfer Switch with Generator Prep
- Battery Quick Disconnect
- 30 Amp Service
- 15,000 BTU Air Conditioner (Select Models)
- Ducted A/C Into Garage
- Large Tinted Safety Glass Windows with 80% Tint
- Rain Gutters with Extended Drip Spouts
- Aluminum "RAM" Air Ventilation System In Garage
- Spare Tire
- 16" "E" Rated Radials
- Heated And Enclosed Underbelly
- Double Welded Aluminum Construction
- Filon Exterior Sidewalls
- Hydraulic Slide Rooms (select models)
- One Piece EPDM Rubber Roof (12 year warranty)

### EXTERIOR

- Outside Shower
- Black Tank Flush
- 30 Gallon Fuel Station
- Exterior Cable / Sat Hook-up
- Outdoor Activity Light
- One Touch Electric Awning
- Easy Glide Radius Steps

### ENTERTAINMENT SYSTEM

- Sony® AM/FM/CD/DVD/MP3 Player
- 4 - Interior Speakers
- 2 - Exterior Marine Speakers

### OPTIONS

- Double Electric Queen Beds with U-Shaped Dinette
- Rear Screen Enclosure
- Onan 4,000 Watt Generator
- Dual Pane Windows

### SAFETY PACKAGE

- Carbon Monoxide Detector
- Smoke Detector
- LP Gas Detector
- Fire Extinguisher



## SPECIFICATIONS & DECOR OPTIONS

FIFTH WHEELS	19FB	22FS	27FS	31DS
SHIPPING WEIGHT	TBD	5540	6760	8850
CARRYING CAPACITY	TBD	4785	4505	4150
HITCH WEIGHT	TBD	635	865	1225
EXTERIOR LENGTH	TBD	26' 2"	31' 0"	35' 5"
EXT. HEIGHT - A/C TOP	TBD	12' 3"	12' 3"	12' 3"
FRESH WATER (GAL.)	TBD	60	60	86
WASTE WATER (GAL.)	TBD	30	30	30
GRAY WATER (GAL.)	TBD	30	39	60
LPG	TBD	40	40	40
AWNING	TBD	16'	18'	16'



TWILIGHT



COGNAC



ECLIPSE

\* Weights reflect a fully equipped coach. See disclaimer on back cover.

WWW.KEYSTONERV-RAPTOR.COM

# RAPTOR



**Keystone RV  
Company**

WWW.KEYSTONERV.COM | 574-535-2100

DISCLAIMER: Product information is as accurate as possible as of the date of publication of this brochure. All features, floor plans, and specifications in this brochure are subject to change without notice. Please also consult Keystone's web site at [www.keystonerv.com](http://www.keystonerv.com) for more current product information and specifications. Tow Vehicle Disclaimer. CAUTION: Owners of Keystone recreational vehicles are solely responsible for the selection and proper use of tow vehicles. All customers should consult with a motor vehicle manufacturer or their dealer concerning the purchase and use of suitable tow vehicles for Keystone products. Keystone disclaims any liability or damages suffered as a result of the selection, operation, use or misuse of a tow vehicle. KEYSTONE'S LIMITED WARRANTY DOES NOT COVER DAMAGE TO THE RECREATIONAL VEHICLE OR THE TOW VEHICLE AS A RESULT OF THE SELECTION, OPERATION, USE OR MISUSE OF THE TOW VEHICLE.

YOUR LOCAL RAPTOR DEALER:

MARCH 2013