

# MORE STANDARD FEATURES MORE VALUE

We've built a reputation for bringing RV owners more standard features for less money for more than 35 years, and it's a reputation we plan to keep.



100% Pre-Delivery Inspection



The Industry's Best RV Warranty



The Leader in Parts & Service



## Dutchmen®

Legendary Innovation. Trailblazing Value.

Dutchmen began in 1988, our long term success comes from never losing focus on our core mission "We work for the customer".

Everything we put into our Aspen Trail LE is designed to help you make memories with family, friends, and fellow travelers along the way.

Length is defined as the distance from the centerline of hitch pin/coupler to rear bumper of trailer. \*\*Our weights represent how most units are built, inclusive of many commonly-ordered options. \*\*\*Fresh water capacity includes water heater capacity.

DISCLAIMER: Product information is as accurate as possible as of the date of brochure publication. All features, floor plans and specifications in this brochure are subject to change without notice. Please consult Dutchmen's website at [www.Dutchmen.com](http://www.Dutchmen.com) for current product information and specifications. Tow Vehicle Disclaimer. CAUTION: Owners of Dutchmen recreational vehicles are solely responsible for the selection and proper use of tow vehicles. All customers should consult with a motor vehicle manufacturer or their dealer concerning the purchase and use of suitable tow vehicles for Dutchmen products. Dutchmen disclaims any liability or damages suffered as a result of the selection, operation, use or misuse of a tow vehicle. DUTCHMEN'S LIMITED WARRANTY DOES NOT COVER DAMAGE TO THE RECREATIONAL VEHICLE OR THE TOW VEHICLE AS A RESULT OF THE SELECTION, OPERATION, USE OR MISUSE OF THE TOW VEHICLE. REFERENCE DUTCHMEN MANUFACTURING OWNERS MANUAL FOR LIMITED WARRANTY DETAILS. © 2023 Dutchmen Aspen-Trail-LE 10-01-2023-Printed in U.S.A.- MY2024

# ASPEN TRAIL LE



## Travel Trailers & Mini Trailers



## Dutchmen®



# ASPEN TRAIL LE

## Make Every Journey Your Own

### Features in Aspen Trail LE

- **Aspen Trail Power Package** - Aspen Trail Power Stabilizers, Power Awning and Power Tongue Jack make setting up and breaking down your campsite a breeze.
- **Large Pass Through Storage** - Carry more camping gear and personal belongings with you.
- **Larger Interior Height** - 82" interior height allows for more head room and storage.

### Aspen Trail LE Travel Trailer

#### Exterior Features:

- Power Awning w/ LED Lights
- Battery Disconnect Switch
- Friction Hinge Entry Door
- Roof Solar & Inverter Prep
- Tankless Water Heater
- Black Tank Flush
- Magnetic Baggage Door Catches
- Oversized Windows
- Spare Tire
- Rain Gutters
- High Output Furnace
- 15,000 BTU Roof Mount A/C (slide - out models)\*

#### Interior Features:

- Residential Queen Bed w/ Storage\*
- Fireplace in ALL Slide-out Models\*
- LED Interior Lighting
- 10 cu. ft. 12V Refrigerator
- 3 Burner Cooktop \*
- Oven\*
- Shower Surround
- Jackknife Sofa
- Galley Sink w/ High Rise Faucet
- Full Extension Drawer Guides Throughout
- Bluetooth Speaker
- No Carpet
- Flush Floor Slide-Outs
- Hinged Entertainment Center w/ Hidden Pantry\*

### More Standard Features

\*Select Floor Plans



All information & specifications are for units manufactured after 10/01/2023



**ASPEN TRAIL LE 21RD**  
Length: 25' 5" Weight: 4,613 lbs. Sleeps: 4-6  
Hitch: 601 lbs. Height: 10' 11"



**ASPEN TRAIL LE 25BH**  
Length: 28' 8" Weight: 4,824 lbs. Sleeps: 6-8  
Hitch: 497 lbs. Height: 10' 6"



**ASPEN TRAIL LE 26BH**  
Length: 30' 8" Weight: 6,099 lbs. Sleeps: 7-9  
Hitch: 836 lbs. Height: 11' 1"

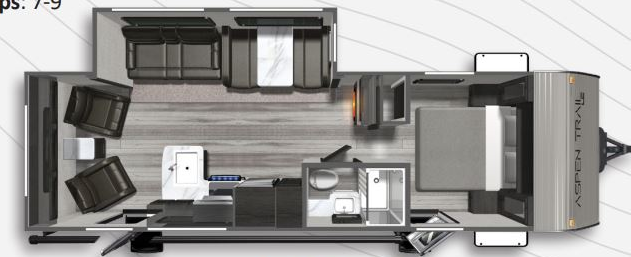

**ASPEN TRAIL LE 26RL**  
Length: 30' 9" Weight: 6,298 lbs. Sleeps: 2-4  
Hitch: 854 lbs. Height: 11' 1"



**ASPEN TRAIL LE 29BH**  
Length: 33' 3" Weight: 6,484 lbs. Sleeps: 7-9  
Hitch: 821 lbs. Height: 11' 3"



**ASPEN TRAIL LE 29TB**  
Length: 33' 9" Weight: 6,72 lbs. Sleeps: 6-8  
Hitch: 1,214 lbs. Height: 11' 3"



Visit [dutchmen.com](http://dutchmen.com)  
for 360 views



## 17 Series



### Exterior Features:

- Power Awning
- Rear Stabilizer Jacks
- Bumper w/Sewer Hose Storage
- 6 gal. LP Water Heater w/DSI
- 20 lb. LP Bottle
- 30 Amp Power Cord
- 35 Amp Converter
- Side Solar Port

### Interior Features:

- High Output Furnace
- 8,000 BTU A/C
- 3.3 cu. ft. 12V Refrigerator
- LED Interior Lighting
- 2 Burner Cooktop
- Microwave
- Galley Sink w/ High Rise Faucet
- Night Shades Throughout
- 40" Booth Dinette



#### ASPEN TRAIL LE 17BH

Length: 21' 5" Weight: 3,069 lbs. Sleeps: 2-4  
Hitch: 396 lbs. Height: 9' 9"



#### ASPEN TRAIL LE 17RB

Length: 21' 5" Weight: TBD Sleeps: 3-4  
Hitch: 544 lbs. Height: 9' 9"



#### ASPEN TRAIL LE 1950BH

Length: 23' 5" Weight: 3,676 lbs. Sleeps: 4-5  
Hitch: 511 lbs. Height: 9' 11"

## Aspen Trail LE Mini



1980BH  
Pictured

### Exterior Features:

- Power Awning
- Rear Stabilizer Jacks
- 20 lb. LP Bottle
- 30 Amp Power Cord
- 35 Amp Converter
- Spare Tire
- Solar Prep w/ Inverter Prep
- Tankless Water Heater

### Interior Features:

- High Output Furnace
- 13.5 Roof Mounted A/C
- 10 cu. ft. 12V Refrigerator
- LED Interior Lighting
- 2 Burner Cooktop
- Microwave
- Galley Sink w/ High Rise Faucet
- Night Shades Throughout
- Upgraded Flooring



#### ASPEN TRAIL LE 1860RK

Length: 21' 5" Weight: 3,577 lbs. Sleeps: 4-5  
Hitch: 475 lbs. Height: 9' 11"



#### ASPEN TRAIL LE 1980BH

Length: 23' 5" Weight: 4,325 lbs. Sleeps: 4-5  
Hitch: 606 lbs. Height: 10' 9"

## More Standard Features



Rear  
Stabilizer  
Jacks



20 lb.  
Propane



Prepped  
for WIFI



Power  
Awning



Efficiency Air  
Conditioner



# ASPEN TRAIL LE



Aspen Trail LE has the most dynamic range of floor plan options to fit any camping style. With more standard features than its competitors and a focus on quality, value, and design, Aspen Trail LE delivers the best RV in its class. Whether your trail leads across this great country or simply a staycation, with Aspen Trail LE make every journey your own.

## DUTCHMEN® CONSTRUCTION ADVANTAGE

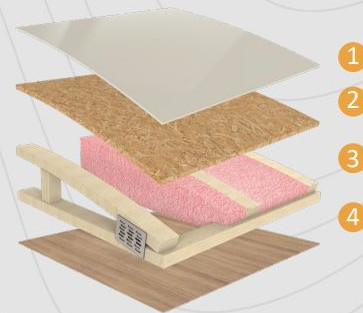

### Durable Roof Structure

- 1 TPO Roof - Lifetime Warranty
- 2 3/8" Decking
- 3 Fiberglass Insulation
- 4 Lauan Interior Panel



### Insulated Structure

- 1 Metal Exterior Panel
- 2 Wood Frame with R7 Thermal Insulation
- 3 Lauan Interior Panel



### Interior Decors



Fabric

Flooring

Woodgrain

Countertops

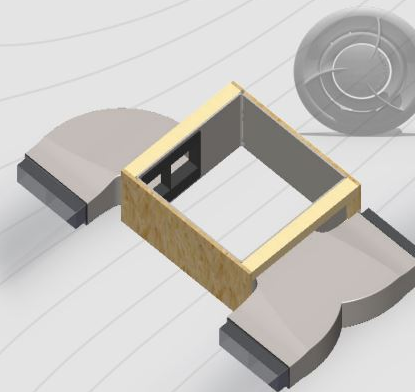

### Blade Air Flow System

This design reduces air turbulence and noise accelerating airflow with duct elbows and wyes that feature enlarged inlets and narrow as they push cooled air from the AC through the length of the ducting.

(On Ducted AC Models Only)

### Your Dealer

Colton RV & Marine  
3122 Niagara Falls Blvd.  
North Tonawanda, NY 14120  
(716) 694-0188  
[www.ColtonRV.com](http://www.ColtonRV.com)

Colton RV  
489 Bushkill Plaza LN #9665  
Wind Gap, PA 18091  
(610) 863-5239  
[www.ColtonRV.com](http://www.ColtonRV.com)

PO BOX 2000 | 2164 CARAGANA COURT | GOSHEN, IN 46527 | SALES 574.537.0600

Scan the QR code with your mobile phone to learn more

