

Coach House[®] Motor Homes

2025 OWNER'S MANUAL



Coach House, Inc.
3480 Technology Drive • Nokomis • Florida
(800) 235-0984 • (941) 485-0984 • (941) 488-4095 FAX
ON THE WEB: WWW.COACHHOUSERV.COM
EMAIL: INFO@COACHHOUSERV.COM



Table of Contents

<u>SECTION 1</u>	<i>INTRODUCTION</i>
<u>SECTION 2</u>	<i>SAFETY GUIDELINES</i>
<u>SECTION 3</u>	<i>WEIGHTS & TOWING</i>
<u>SECTION 4</u>	<i>MOTOR HOME OPERATION</i>
<u>SECTION 5</u>	<i>APPLIANCE AND EQUIPMENT</i>
<u>SECTION 6</u>	<i>ELECTRICAL SYSTEMS</i>
<u>SECTION 7</u>	<i>WATER AND PLUMBING SYSTEM</i>
<u>SECTION 8</u>	<i>LP GAS SYSTEM</i>
<u>SECTION 9</u>	<i>MAINTENANCE / MISCELLANEOUS</i>
<u>SECTION 10</u>	<i>GENERAL INFORMATION</i>



WARNING

Operating, servicing and maintaining a motor vehicle can expose you to chemicals including engine exhaust, carbon monoxide, phthalates, and lead, which are known to the State of California to cause cancer and birth defects or other reproductive harm. To minimize exposure, avoid breathing exhaust, do not idle the engine except as necessary, service your vehicle in a well ventilated area and wear gloves or wash your hands frequently when servicing your vehicle.

For more information go to
www.P65Warnings.ca.gov/passenger-vehicle

SUPPLEMENTAL INFORMATION (ADDENDUM)

Located in the back of the Coach House preprinted owner's manual are informational packets and / or manuals from our suppliers.

OR AS

SEPARATE ELECTRONIC PDF SUPPLEMENTAL INFORMATION

Please refer to these documents for detailed information regarding the actual devices and equipment which were installed at the time of manufacture.

Please note the manufacturer's warranties may differ from the Coach House Limited warranty, or may need to be activated at the time of purchase.

SECTION 1

INTRODUCTION

Introduction	1-2
Letter from the Owners	1-3
Ambassador Program	1-4
Coach House Owner's Club	1-5
Family Motor Coach Association	1-7
Quality Standards	1-9
Warranty Coverage	1-10
Warranty Process	1-11
Appliance Warranty Information	1-14
Reporting Safety Defects	1-15
Safety Recalls	1-16
Florida Lemon Law	1-16

INTRODUCTION

Every effort has been made to build your  *Coach House* Motor Homes RV to the highest quality standards. To help you obtain the most enjoyment and safety while using your motor home, we strongly urge you to carefully review this owner's manual, paying particular attention to the areas that discuss safety. Some items discussed are optional and only need to be reviewed if that option has been installed on your unit.

The Coach House owner's manual is comprised of many parts:

- 1) **Chassis Owner's Manual** - The Chassis Owner's Manual is supplied by:



Ford Motor Company

OR



Mercedes-Benz.

Please pay specific attention to the recommended service guidelines for your chassis in order to ensure a long life of the engine, frame, suspension, tires, and auxiliary equipment which was provided by the chassis manufacturer.

- 2) **Safety Guidelines** - (Section 2) This section is a comprehensive guide to the safe operation of any Recreational Vehicle.
- 3) **Area Specific Breakdowns** - (Sections 3 - 8) These sections have general instructions and guidelines for all areas of your motor home. If you cannot find the information needed please refer to the addendum in the back of your printed binder. Otherwise, refer to the electronic PDF supplemental information provided. If more information is needed feel free to call our service department at the factory, or call the manufacturer with the contact numbers provided in this manual.

Our telephone number is **1-800-235-0984**.

This manual is meant to give the owner a good understanding of the family of products. Coach House, Inc. should be consulted for specific information concerning your equipment.

Thank you for your purchase,



The Coach House Production Team

LETTER FROM THE OWNERS

Dear Valued Coach House Owner,

Welcome to the Coach House family! We are thrilled that you have chosen one of our premium motor homes as your trusted companion for countless adventures. At Coach House, we take great pride in the craftsmanship and quality of our motor homes, and we are committed to ensuring your satisfaction and peace of mind.

This Warranty Manual is designed to provide you with comprehensive information regarding the warranty coverage for your Coach House Motor home. Within these pages, you will find detailed explanations of the warranty terms and conditions, as well as guidance on how to maintain your motor home to keep it in optimal condition.

We understand that purchasing a motor home is a significant investment, and our goal is to support you every step of the way. Our warranty coverage is a testament to the confidence we have in the durability and reliability of our products. Should you encounter any issues, our dedicated customer service team is here to assist you, ensuring that any concerns are promptly addressed.

Please take the time to read through this manual carefully. It contains valuable information on your responsibilities as a motor home owner, as well as essential maintenance tips to extend the life of your vehicle. Regular maintenance and adherence to the guidelines provided will help you enjoy your motor home for many years to come.

Thank you for choosing Coach House Motor homes. We are honored to be part of your journey and look forward to providing you with exceptional service and support. If you have any questions or need assistance, please do not hesitate to contact our customer service team at 1-800-235-0984.

Safe travels and happy adventures!

Sincerely,

Steve Gerzeny
Vice President
Coach House, Inc.

AMBASSADOR PROGRAM

The Coach House Ambassador Referral Program was created to entice our valued customers to share their experience with friends, family, and everyone you meet during your travels! It is a common occurrence to be stopped by people asking about your Motor Home. Why not get paid for your time and efforts?

Here is how it works:

- Sign up to be an ambassador. We will custom print and mail you a packet of Coach House Ambassador business cards with your name and our contact information.
- When approached by a prospect, simply discuss your Coach House Motor home. Explain the features and benefits, the styles/models and why you purchased.
- Hand them a Coach House Ambassador business card and tell them to contact us directly at the Factory.
- If a prospect purchases any model, Coach House, Inc. will pay you \$200.00 once the unit is delivered. There's no limit to the number of people you can refer, so there's no limit to how much you can earn!

We sincerely appreciate your assistance. Good Luck and Fun Selling!!!

Sincerely,

Steve Gerzeny
Vice President
Coach House, Inc.

COACH HOUSE OWNER'S CLUB

As an owner of a Coach House product, you have the right to join the

C.H.O.C. (Coach House Owner's Club)

This sub-chapter of the F.M.C.A. (Family Motor Coach Association) will automatically put you in contact with other Coach House Motor home owner's and enthusiasts.

This club spearheads the active motor home lifestyle, specifically for owners of the Coach House brand and their friends.

Look forward to receiving the C.H.O.C. newsletter which will keep you up to date on all the happenings with the club - including invitations to member's rallies where you can meet your new friends in person and enjoy the R.V. Lifestyle.

We have included the membership application at the back of the printed manual binder. Coach House, Inc will pay for your first year membership on any new purchase. Ask for details.

Congratulations! and many safe travels with your new friends...

You can view the club website at:

<https://coachhouseownersclub.com>

A Message From The President

Welcome to the Coach House family! As President of the Coach House Owners' Club (CHOC), and on behalf of all of our members, I would like to extend this invitation to you to join our fun and friendly club.

CHOC is made up of like-minded people who share the common bond of owning a quality Coach House motor home for their recreational pursuits. Our rallies — such as Spring 2018 to Memphis, Tenn. and Fall 2018 to Asheville, N.C. — are fun times for exploring new locations, sharing experiences, getting together with old friends and making new ones. When we're not on the road, we keep in touch through our *CHOC Talk* newsletters which are published twice yearly, and our CHOC Facebook group page, which is a private forum for members only. We also have our own club web site.

You may complete the application in this flyer, or you may download an application at CoachHouseRV.com, or you may email me directly at President@coachhouseownersclub.com or CHOC Membership Officer Renee Rodeck at Memberships@coachhouseownersclub.com. Applications are also available from Coach House directly (1-800-235-0984). We look forward to meeting you.

Sincerely,
David Wedemeyer,
President

Member Benefits

Membership in the Coach House Owners' Club provides the following benefits:

- Camaraderie with Coach House owners
- CHOC Newsletter
- CHOC private Facebook group
- Full access to the CHOC web site, www.coachhouseownersclub.com
- Coach House activity options
- Chapter rallies
- FMCA benefits (for information on FMCA and how to join, see www.fmca.com or call FMCA at (800) 543-3622).

Find Out More

For more information about the Coach House Owners' Club, please contact one of the club's current officers:

David Wedemeyer, President
President@coachhouseownersclub.com

Renee Rodeck, First V.P., Membership
Memberships@coachhouseownersclub.com

Ruth Ristow, Bill Ristow, Irene Wedemeyer
Second V.P., Rally Coordinator
RallyCoordinator@coachhouseownersclub.com

Charlie Hedstrom, Third V.P., Communications
Communications@coachhouseownersclub.com

Helen Paul, Secretary
Secretary@coachhouseownersclub.com

Val Baselle, Treasurer
Treasurer@coachhouseownersclub.com

Mike Thurstby, FMCA National Director
FMCA@coachhouseownersclub.com

Ross Hendrix, FMCA Alternate National Director
AltFMCA@coachhouseownersclub.com

Lori Pierce, Coach House Factory Liaison
lpierce@coachhousesrv.com

Coach House Owners' Club FMCA Chapter Membership Application

LAST NAME FIRST NAME
PILOT # / #

LAST NAME FIRST NAME
CO-PILOT # / #

STREET ADDRESS #

CITY, STATE, ZIP #

PHONE #

E-MAIL #

COACH MODEL NUMBER (E.G. 272) & YEAR #

FMCA NO #

Please indicate: New membership Renewal

Please check if you are a past member of CHOC.

Please check if you DO NOT want your information included in the CHOC roster that is only distributed to members.

Please check if you DO NOT want to be added to the CHOC secret and private Facebook Group.

No person may be a member of the Coach House Owners' Club unless he or she is a member in good standing of the national organization of the Family/Motor Coach Association (FMCA) and a current or former Coach House owner.

Fees: \$25 to join CHOC; \$25 per year thereafter.

Please send this application and a check for \$25, payable to Coach House Owners' Club, to: CHOC, c/o Coach House, Inc., 3480 Technology Drive, Nokomis, FL 34275.

Name Tag Info

PLEASE PRINT CLEARLY

NAME PILOT GOES BY #

NAME CO-PILOT GOES BY #

YOUR HOMETOWN (CITY, STATE) #

STREET ADDRESS TO MAIL NAME TAGS, IF DIFFERENT FROM ABOVE: #

CITY, STATE, ZIP #



DETACH & RETURN NOW!
OR SIGN UP AT
FMCA.com/invite
USING PROMO CODE:
C007578

Welcome to your new RV! There's a lot to learn – and love – about RV life, and the best resource for information, discounts, on-the-go assistance and more is the Family Motor Coach Association (FMCA).

That's why we are sending you an invitation to enjoy a FULL YEAR of complimentary membership – at NO cost to you!

Here's what you need to do right now:

RETURN THE MEMBERSHIP VOUCHER BELOW
 or Visit **FMCA.com/Invite** With Your Unique Promo Code Found Above

This will get you started on your complimentary membership and all the great benefits that come with being a new member of FMCA. Benefits like select pricing on RV tires, \$74 Roadside Resuce®, and our very own **FMCassist Medical Emergency and Travel Assistance Program** (included in your

Over, please...

Your Membership is Courtesy of



We are pleased to present you with this complimentary membership (a \$60 value). Congratulations on your RV purchase!

DETACH HERE ▶

DETACH HERE ▼

MEMBERSHIP ACCEPTANCE VOUCHER

YES! Activate my complimentary FMCA membership today!

Please change my address of record to:

ADDRESS _____

CITY _____

STATE _____ ZIP _____

The following information will be added to your membership.

CO-PILOT LAST NAME / FIRST NAME _____

Motorhome Towable _____
 RV MAKE & MODEL _____

AREA CODE / PRIMARY PHONE _____ EMAIL _____ PROMO CODE: C7578JUN19

Look at the back of printed binder for card to mail in.

membership!). For more FMCA benefits, see the sidebar to the right.

Members tell us they wouldn't hit the road without their FMCA membership, and now you don't have to, either – and this is at absolutely NO cost to you. Your membership (\$60 value!) is a thank-you from FMCA for joining the wonderful world of RV ownership.

Welcome to the FMCA, Your RVing Family!

Sincerely,



Chris Smith
Executive Director/CFO

P.S. Please return your Membership Acceptance Voucher or go online immediately so we can get your distinctive FMCA RV plates on their way to you.

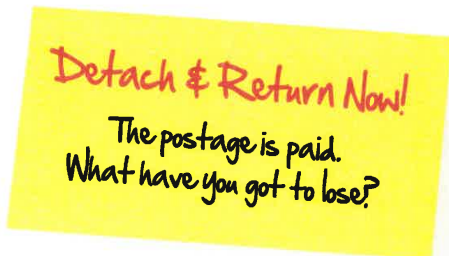

This one-year FMCA complimentary membership offer is not applicable to individuals who have been a member in the past, or presently have an active membership.

VISIT US ONLINE AT
www.fmca.com

BUSINESS REPLY MAIL
FIRST-CLASS MAIL PERMIT NO. 10926 CINCINNATI OH
POSTAGE WILL BE PAID BY ADDRESSEE

FAMILY MOTOR COACH ASSOCIATION
8291 CLOUGH PIKE
CINCINNATI OH 45244-9928

NO POSTAGE
NECESSARY IF
MAILED IN THE
UNITED STATES

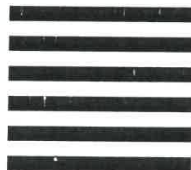

All Members Receive...

INFORMATION EXCHANGE

- Family RVing magazine
- FREE Directory/Member Benefits Guide
- Access to educational programs
- Full member access to FMCA.com and familyrvingmag.com

TRAVEL SERVICES

- FREE FMCAssist, the Medical Emergency and Travel Assistance Program (\$105 value!)
- FMCA Roadside Rescue® – U.S. and Canada

INSURANCE

- FMCA RVinsurance – competitive rates on RV, homeowners, and auto insurance
- FMCA International Travel Insurance
- Affordable healthcare options for RVers

ACTIVITIES

- International RV Showcase events
- Over 400 special-interest and geographic chapters to join
- Chapter & area rallies

DISCOUNTED RATES

- Special pricing via the FMCA Tire Savings Program
- FREE 1-year KOA Value Kard Rewards trial membership
- Discounted rates at hundreds of FMCA commercial member campgrounds
- Special offer from Passport America
- Special discounts on Fantasy RV Tours
- Travel-friendly mobile internet offers with FMCA Connect-on-the-Go and FMCA TechConnect+
- Special offer from Costco Wholesale Membership Program (\$50 value!)
- \$10 Gift Card for New Sam's Club Members
- Office Depot and Staples National Discount Programs
- Save on RV temperature monitoring for your pets

ADDITIONAL BENEFITS

- FMCA identification emblems
- Anti-theft program for your RV
- 20 FREE words of Classifieds advertising

Additional sign-up and fees may be required for some benefits.

QUALITY STANDARDS

Coach House, Inc., has been recognized by the Ford Motor Company as a Qualified Vehicle Modifier (QVM) and by Mercedes Benz, U.S.A. as a Expert Upfitter. This means that each Coach House adheres to strict guidelines, quality controls, and is built to ensure optimization to the vehicle chassis. Our plant is subject to inspections at any time by Ford or Mercedes Benz. We comply with all manufacturer notices and advisories to ensure your safety and long-term enjoyment of your premium chassis as the power-plant which is the heart and soul of your Coach House Motor Home.



Coach House Motor Homes are “Built in the USA” in Nokomis, Florida. We take great pride in our entire lineup. We are also an active and proud member of RVIA, the Recreational Vehicle Industry Association. Much like Ford and Mercedes Benz, RVIA conducts random inspections throughout the year to verify that Coach House, Inc. is in compliance with the latest updates to building codes and standards of the RV industry. Each of our Coach House Motor homes are built with these standards and quality during production.



WARRANTY COVERAGE

This document is intended to provide a general guideline regarding the warranty of your new Coach House Motor home. The original Coach House, Inc., Limited Warranty form was signed by you when you purchased and took delivery of your new unit and is the only document which governs the Coach House, Inc. limited warranty. Coach House, Inc. reserves the right to make changes to the limited warranty at any time at its' sole discretion.



Coach House, Inc. warrants the conversion portion of the motor home for a period of three (3) years or thirty-six thousand (36,000) miles from the date the first retail purchase or first in-service date.



Ford chassis are warranted for a period of three (3) years or thirty-six thousand (36,000) miles from the date of delivery, whichever comes first. Ford also provides roadside assistance in the event you are stranded or need help while traveling. The Powertrain is warranted for five (5) years or sixty thousand (60,000) miles from the date of delivery, whichever comes first.



Mercedes Benz Chassis are warranted for three (3) years or thirty-six thousand (36,000) miles from the date of delivery, whichever comes first. Also included is 3 years, or 36,000 miles of Roadside Assistance. The powertrain and corrosion resistance are warranted for five (5) years or one-hundred thousand (100,000) miles from the date of delivery, whichever comes first. California and certain other states require special warranty limits. Please consult your chassis manual to verify your coverage.

Manufacturer's Component Warranty

Appliances and auxiliary equipment carry warranties from the individual manufacturer. Please refer to the original equipment manuals included in this Owner's Manual. The warranty period applies only to units used for recreational travel and family camping.

If you have questions about warranty coverages, please email: customerservice@coachhouserv.com for information.

WARRANTY PROCESS

Understanding warranty is confusing at times. Please use the following guidelines to help making the warranty process easier.

- 1) If you have an emergency - Get help immediately. If you smell propane or smoke DIAL 911 and protect yourselves and your motor home.

- 2) If you have an issue with your FORD or MERCEDES product (examples include engine, transmission, drive train, chassis air conditioning) go to your nearest FORD or MERCEDES authorized service center. There is no need to get approval from Coach House. The warranty is based on your VIN number and your local FORD or MERCEDES dealer can help you.

- 3) Coach House asks for “pre-approval” for warranty items we are responsible for. If we manufactured, or created a part during the conversion of your motor home, please call us to let us know you have an issue. If you can find a qualified service center near you - we will work with them to approve reasonable charges. We may send them the parts they need to complete the repair.

If necessary, we may ask you to bring the motor home back to the factory in Nokomis, Florida for repairs.

Call 1-800-235-0984 to “pre-approve” your warranty issues.

You can also email: customerservice@coachhousesrv.com and we will respond.

- 4) Manufacturers have different warranties. Coach House did not make the A/C, the refrigerator, the water heater, etc. We can help you figure out the process to obtain service for appliances which we did not manufacture - but installed. We work closely with our suppliers - and usually can help you find the best phone number to get help in a reasonable amount of time

Call 1-800-235-0984 for information about manufacturer warranty.

You can also email: customerservice@coachhousesrv.com for information

What is covered?

Defects in material and workmanship caused by Coach House, Inc.

What is NOT covered?

1) Adjustments

EXCEPTION - The following items will be adjusted free of charge for a period of ninety (90) days after retail purchase:

- a. Cabinet Doors
 - b. Cabinet Drawers
 - c. Latches
 - d. Entry Doors, steps, and striker plates
 - e. Awnings
 - f. Loose Trim
 - g. Slide-out adjustments
- 2) Fuses and Light Bulbs
- 3) Any product not registered and normally used in the United States or Canada.
- 4) Components that are warranted separately by the manufacturer of the product, including but not limited to chassis, tires, batteries, generators, plumbing, electrical equipment, air conditioners, furnaces, audio equipment, furniture, upholstery, and appliances.
- 5) Any product used for commercial purposes, as a permanent residence, or as a rental unit.
- 6) Window glass breakage. Headlights, Taillights.
(Unless noted at the time of delivery)
- 7) Lubrication and minor adjustments of locks, latches, hinges, slide-out system, etc.
- 8) Rust, corrosion, oxidation, dents, and other damage as a result of environmental conditions such as, but not limited to, heavy winds, hail, lightning, salt, and sand.
- 9) Fading or normal deterioration of items such as fabrics, exterior paint, decorative items, carpet, etc. due to use or exposure to ultra-violet rays or sun. Coach House does not warranty the conversion due to excessive climate conditions.
- 10) Cleaning of undercarriage/frame - Units delivered during winter months are likely to have been exposed to highway salts and chemicals. It is the responsibility of you, the owner, to wash the frame and undercarriage of the unit to prevent damage from rusting or oxidizing.

- 11) Damage/fading of the exterior caused by chemical cleaning or lack of proper maintenance of the exterior.
- 12) Normal unit maintenance, such as inspecting and resealing exterior seams.
- 13) Damage caused by abuse, misuse, negligence, condensation, overloading, vandalism, collision, road hazards, acts of nature (hail, wind, heavy rain damage, acid rain, flood), rock chips, alterations or modifications, improper non-warranty repairs, lack of normal maintenance, failure in giving prompt notice of water damage, improper operation or storage of components.
- 14) Subsequent damage, loss, or injury beyond warranty repairs as a result of mold or fungi.

15) Any additions, modifications, alterations etc, not installed by Coach House can affect your warranty. It is important to note that any changes made can void the manufacturer's warranty. This is because changes can alter the original design, functionality, and safety features of the performance or safety of an RV that has been altered from its factory specifications. Therefore, owners should be aware that they assume full responsibility for any repairs or problems that arise from modifications, as these will not be covered under the original warranty.

APPLIANCE WARRANTY INFORMATION

Appliances installed by Coach House are warranted by the individual appliance manufacturers; refer to the Coach House Limited Warranty. Some of the manufacturers include a list of authorized service centers with their instruction manuals. The following is a partial list of appliance manufacturers with their phone numbers you should call if you experience any problems while under warranty.

Appliance / Item	Manufacturer	Location	Phone Number
Air Conditioner	Dometic	Elkhart, IN	(800) 544-4881
Awning (Motorhome)	Girard Products	San Clemente, CA	(949) 259-4024
Awning (Slide-Top)	Dometic	Elkhart, IN	(800) 544-4881
Batteries	Battle Born 200AH	Reno, NV	(775) 622-3448
	Epoch 600AH	Stockbridge, GA	(888) 501- 1846
Converter	Progressive Dynamics	Marshall, MI	(269) 781-4241
Furnace	Suburban	Dayton, TN	(423) 775-2131
Generator	Onan	Minneapolis, MN	(800) 888-6626
Home Theater	BOSE	Framingham, MA	(800) 367-4008
Hydraulics	HWH Corporation	Moscow, IA	(800) 321-3494
Inverter	Xantrex	Elkhart, IN	(800) 670-0707
LPG Tank	Manchester Tank	Lynwood, CA	(800) 640-6327
Leveling System	Bigfoot	White Pigeon, MI	(800) 752-9815
Microwave	High Pointe	Bristol, IN	(574) 848-4256
Monitor Panel	Garnet	Sherwood Park, AB	(800) 617-7384
Refrigerator	Norcold	Sidney, OH	(800) 354-4135
	Nova Kool	Coquitlam, B.C.	(604) 523-6515
Roof Vent	Maxxfan	Wichita, KS	(574) 247-9235
Range Hood	Ventline/Dexter	Bristol, MI	(574) 848-4491
Step, Entry	Libbert Components	South Beno, IN	(574) 537- 8900
Stove Top	Dometic	Elkhart, IN	(574-389-3702
TV	Samsung	Ridgefield Park, NJ	(800) 726-7864
TV Antenna	Winegard	Burlington, IA	(800) 288-8094
Water Closet (Toilet)	Thetford	Ann Arbor, MI	(800) 543-1219
Water Heater	Truma	Elkhart, IN	(855) 558-7862
Van Awnings	Carefree of Colorado	Broomfield, CO	(800) 622-3230

SPECIAL NOTE: Some warranty cards are included to be filled out and mailed, while other warranties can be filled out online.

REPORTING SAFETY DEFECTS

If you believe that your vehicle has a defect which could cause a crash or could cause injury or death you should immediately inform the National Highway Traffic Safety Administration (NHTSA) in addition to notifying Coach House, Inc.

If the NHTSA receives similar complaints, it may open an investigation, and if it finds that a safety defect exists in a group of vehicles, it may order a recall and remedy campaign. However, NHTSA cannot be involved in individual problems between you, a vendor or Coach House, Inc.

To contact NHTSA, you may either call the Auto Safety Hotline toll-free at:

1-800-424-9393

or 202-366-0123 in the Washington D.C. area

or write to:

NHTSA Headquarters

1200 New Jersey Avenue, SE

West Building

Washington, DC 20590

or:

www.NHTSA.dot.gov

You can also obtain other information about motor vehicle safety from the hotline.



U.S. Department of Transportation

**National Highway Traffic Safety
Administration**

SAFETY RECALLS

In the event that there is a Safety Recall on your vehicle or any component therein, you will be notified, in writing, by Coach House outlining the steps you need to take to remedy the situation.

To see a complete description of the Recall process and requirements, please go to the following government web site:

<https://www-odi.nhtsa.dot.gov/recalls/documents/recompendium.pdf>

If you want to check for recalls from your vehicle manufacturer, go to:

www.safercar.gov

Then enter your full 17-digit VIN number.

FLORIDA LEMON LAW

We have included a pamphlet from the Florida Department of Agriculture and Consumer Services outlining the basic aspects of the Florida Lemon Law. Please pay close attention to Pages 8 - 11 which refer to Recreational Vehicles.

If you have any questions please call:

1-800-321-5366

or

1-850-488-2221 (outside Florida)

SECTION 2

SAFETY GUIDELINES

R.V.I.A	2-2
Safety Labels	2-3
General Safety	2-4
Alarms	2-5
Combination LP/CO Detector	2-6
Smoke Detector	2-7
Fire Prevention	2-8
Fire Extinguisher	2-9
Fuel and Propane Safety	2-10
Emergency Escape - Egress Windows	2-11

R.V.I.A.

Coach House, Inc. is a proud member of the RVIA
(Recreational Vehicle Industry Association).



**RECREATION VEHICLE
INDUSTRY ASSOCIATION**

The RV Industry Association's standards inspection program is one of the organization's signature industry initiatives and its greatest member benefit. The standards department maintains a professional team of full-time inspectors that promote the enhancement of safety by monitoring adherence to the standards adopted by the Board of Directors for the construction of RVs and Park Model RVs. The team conducts more than 2,000 unannounced inspections of member company RV manufacturing plants annually and is committed to providing educational resources, and hands-on training to manufacturer members to support their commitment to comply with these adopted codes and standards.



The RVIA seal is located to the left of the main passenger side door hand rail.
Each RVIA seal is unique and individually numbered.

DO NOT REMOVE THE RVIA SEAL FROM YOUR RV

SAFETY LABELS

Safety, comfort, and ease of operation are key considerations during the design and manufacture of all Coach House Motor homes. It is the responsibility of the owner and operator to read, understand, and follow all instructions in this manual, all appliance/equipment system manuals located in the packet at the back of this manual, and be familiar with all labels or signs in the motor home. Specific items, procedures or instructions are identified with the keywords “**DANGER**”, **WARNING**, and “**CAUTION**” which emphasize areas of special concern. These keywords are defined as follows:



DANGER

DANGER - Indicates a hazardous situation which, if not avoided, **WILL** result in serious injury or death.



WARNING

WARNING - Indicates a hazardous situation which, if not avoided, **COULD** result in serious personal injury or death.



CAUTION

CAUTION - Indicates a hazardous situation which, if not avoided, **COULD** result in minor or moderate personal injury and/or damage to the motorhome.



NOTICE

NOTICE - Identifies hazards not related to personal injury.

The safety symbol,  used in conjunction with the **DANGER**, **WARNING**, and **CAUTION** labels identifies an area that involves the personal safety of the operator, passengers, or bystanders. Read, understand, and follow the instructions and information in the safety label, sign or manual. Do not take chances with safety. Most accidents are preventable.

Follow the safety precautions outlined in this manual, but keep in mind that the manual may not cover all situations. Every person who occupies the motor home or operates any of its components, devices or sub-assemblies must be familiar with this manual and the manuals in the “Packet” at the back. Every operator and occupant is responsible for following all safety items covered in this and other manuals.

GENERAL SAFETY

1. The most important safety feature on your motor home is a knowledgeable operator. It is their responsibility to read, understand, and follow the safety and operating instructions regarding the, chassis, appliance and system manuals. Most accidents that involve motor homes are preventable.
2. An operator who has not read and understood all operating and safety instructions is not qualified to operate the motor home.
3. Untrained or uninformed operators expose themselves, passengers and other individuals to possible injury or death, and they subject the motor home, other vehicles and property to potential damage.
4. Do not modify the motor home in any way. Unauthorized modifications may impair the function and/or safety of the motor home. In certain cases, modifications may void your warranty.
5. All driver and passenger seats are equipped with seat belts. Occupied seats must be locked in the forward facing direction when the motor home is moving, and passengers may occupy only approved seats with the seat belt securely fastened. Do not allow any passengers to travel in the motor home unless they are in an approved seat with the seat belt secured. Motor home seats with seat belts installed by the manufacturer are the only seats approved and safe for travel.
6. Always fasten the seat belt low on the torso and keep it snug to transmit the force from the belt into the hip/pelvic region of the body. Pregnant women should wear a lap/shoulder belt whenever possible. Wear the belt snug and low throughout the pregnancy.
7. Establish a monthly fire extinguisher inspection program to ensure the extinguisher is fully charged and in proper working condition. Inspect the extinguisher prior to each time you operate or occupy the motor home.
8. Regularly checking your RV smoke detector is crucial for ensuring your safety on the road. Start by testing the alarm monthly using the test button to confirm it's working properly. Replace the batteries at least once a year, or immediately if the detector starts beeping intermittently, signaling low power. Additionally, clean the detector with a vacuum or a soft brush to remove dust and debris that could impair its function. Always follow the manufacturer's instructions for maintenance and replacement to ensure your smoke detector remains reliable.
9. Regularly checking and replacing your RV's carbon monoxide (CO) and propane (LP) detectors is essential for your safety. Test the detectors monthly using a test button to ensure they are functioning correctly. Replace the batteries at least once a year or when the device signals low power with beeping sounds. Detectors typically have a lifespan of 5 years, so adhere to the manufacturer's recommendations or replacement. Clean the units regularly to remove dust and debris that could affect their performance. Proper maintenance and timely replacement of CO/LP detectors are vital for detecting hazardous gases and preventing potential poisoning.

ALARMS

Your Coach House Motor home has been equipped with detectors which will sound an audible alert if the accumulation of harmful non-visible gases or smoke occurs. If you hear the alert, exit the motor home immediately and seek professional help to establish the safety of the air quality inside your motor home. You can not smell these gases in many cases, so the safety of your motor home could be in danger. If you see or smell smoke, DIAL 911 and get help. Always assume levels of gases are potentially harmful if the audible “alert” sound is heard.



CAUTION

Recurring alarms indicate the slow accumulation of LP gas, Carbon Monoxide or Smoke and may warn of low battery levels. Have an authorized service center check the system and identify the source of the alarm. Correct the problem before using the motor home. Keep all alarms in good working order. For detailed information, refer to the alarm manuals provided in the back of the printed binder or the electronic manual package.



DANGER

Carbon Monoxide is a colorless and odorless gas that is lethal to humans and pets. Do not breathe heating or cooking fumes or engine exhaust to prevent asphyxiation.



NOTICE

The 5 Year Alarm Rule

IMPORTANT: Audible alarms should be replaced within five (5) years of their production date. You should record the production date of alarms and keep it available for reference. The replacement date indicates the date beyond which the device may no longer detect Liquid Propane Gas, Carbon Monoxide or Smoke. The date of manufacture of the alarm is stamped on the back of the unit. You may have to remove some screws to get to the backside of the alarm unit for inspection.

COMBO LP GAS / CO DETECTOR

Use of the motor home is not recommended without a working LP / CO gas detector installed.

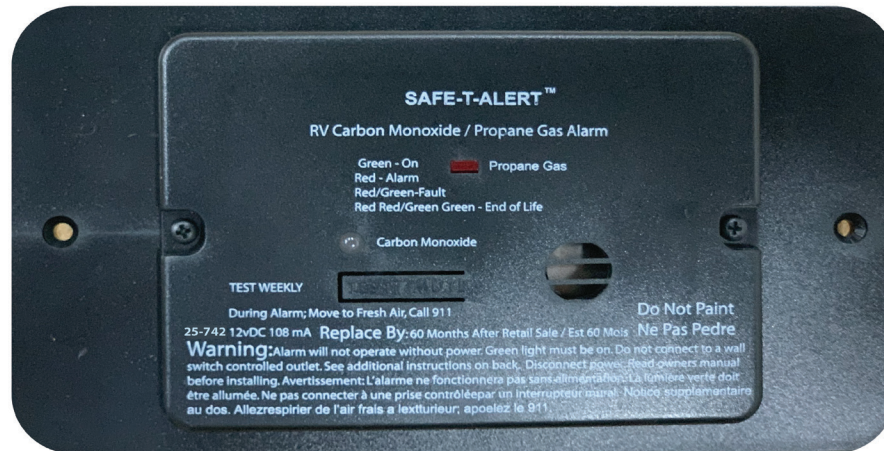

The Combo LP Gas / CO detector is mounted along the base of the cabinets, the location will vary depending on floor plan.

LP Gas is heavier than air so it will settle at the base of the motor home. It also has an odor additive which smells like rotten eggs so that it is readily detected when a leak is present. If the alarm makes an audible “alert” sound - exit the motor home immediately.

Carbon Monoxide is an odorless gas that can be deadly. The audible “alert” sound is the only way to quickly know there is an accumulation of this gas. If the alert goes off, exit the motor home immediately, leave all doors and windows open and have your vehicle checked by a certified RV Technician.

Test the LP/CO alarm after removing the motorhome from storage, before each trip, and weekly thereafter.



If you smell gas, immediately follow these steps:

1. Extinguish open flames, pilot lights and all smoking material.
2. Do not touch any electrical switches.
3. Shut off L.P. Gas tank valve.
4. Open doors, windows, and roof vents after making sure the roof vent fans are “OFF”.
5. Leave the motorhome and it’s immediate vicinity until odor is gone.
6. Have a qualified service technician check the system for leaks and make any necessary corrections and repairs.

SMOKE DETECTOR

A smoke detector is mounted near the ceiling close to the entry door. The detector is battery operated (9 volt) and should be tested on a regular basis. Refer to the manufacturers instruction sheet for the proper testing procedure and battery replacement. The smoke detector should be tested after each time the motor home has been in storage, before each use and at least once each week during use of the motor home. Smoke detectors should be replaced periodically as per the manufacturer's instructions. The smoke detector sounds whenever there is an unsafe amount of smoke in the motor home. Always open the roof vent before cooking.



WARNING

**Have an escape plan and test it before using the motor home!
Identify the emergency exits!**

IF ALARM SOUNDS:

1. Locate the source of smoke.
2. If in doubt, evacuate immediately.
3. Open doors, windows and roof vents to air out the motor home and silence the alarm.
4. Eliminate the source of the smoke.
5. Replace the BATTERY every 6 months or if alarm beeps randomly because BATTERY power is low.
6. Test the smoke alarm every few weeks. Depress test button until alarm sounds.
7. Test the smoke alarm sensor by blowing smoke from a safe source past the sensor. If the alarm does not sound identify, correct the problem or replace the smoke detector.
8. Make sure the wires are correctly connected to the battery. Position and close cover.
9. If you suspect the smoke alarm is not functioning properly, replace the alarm.

DO NOT ATTEMPT TO REPAIR IT

Regardless of whether the Smoke Detector appears to be functioning correctly, it should be replaced in 5 years with a new unit specified for RV use. Change battery at least once a year, and test the smoke detector after battery replacement. Clean and vacuum opening on smoke alarm once a month.

**WARNING**

Do NOT remove the battery to silence the alarm. If alarm “beeps” every minute, the battery is weak and requires replacement. Do not allow the battery to go dead. Use only recommended replacement batteries (see Smoke Detector operator’s manual.)

**NOTICE**

Smoke alarms are not perfect and do not respond in all situations. The best safeguard is fire prevention.

FIRE PREVENTION

Fires can start in a variety of ways including, but not limited to: smoking, malfunctioning appliances or equipment, placing flammable materials on hot surfaces, etc. It is best to prevent fires, but be prepared to extinguish a fire if necessary. Review the following sections with all operators and occupants on a regular basis.

**CAUTION**

Any exterior heat source (BBQs, space heaters, etc.) must be positioned away from the side-wall and directed away from the motor home.

FIRE SAFETY TIPS:

1. Establish and maintain good housekeeping practices. Never allow combustible materials to accumulate in or around the motor home.
2. Do not place or store flammable liquids on board the motor home, because fire or explosion may result. Failure to comply could result in serious injury or death.
3. Have fully charged fire extinguishers readily available.
4. Avoid using flammable products in the motor home.
5. Never smoke in bed or when relaxing on the couch.
6. Do not overload electrical outlets.
7. Do not leave food unattended when cooking.
8. Keep children away from electrical outlets and LP gas controls.
9. If there is a fire, evacuate everyone immediately. Use your fire extinguisher if safe to do so and close all LP gas valves if possible. Call the fire department and stay a safe distance away from the motor home until the fire officials declare it safe.

FIRE EXTINGUISHER

A fire extinguisher is located in your Coach House PLATINUM just inside the passenger door. The gauge on the unit should be checked periodically for pressure level. If the indicator is in the red, the unit should either be re-charged or replaced. Fire extinguisher location will vary depending on floor plan.



(On Galley Wall)

- 1- Pull
- 2- Aim
- 3- Squeeze
- 4- Sweep



(Behind Passenger Seat)



WARNING

Use of the motor home is not recommended without a working fire extinguisher installed.

FUNCTION:

Fire extinguishers are designed to put out fires in its initial stages. Once you cannot get within 10 feet of the fire, it is out of control and too big to fight with your extinguisher.

Do not discharge your fire extinguisher to test it. Once it is discharged, even for a few seconds, it will lose pressure and become useless.

Periodically check the pressure gauge on your fire extinguisher. If it loses pressure, the dry chemical will not effectively discharge. Do not operate or occupy the motor home without a fully charged fire extinguisher.

OPERATION:

1. Pull the safety pin and grasp the fire extinguisher firmly by the handle while holding it in an upright position.
2. Aim the fire extinguisher nozzle at the base of the fire. Do not spray the smoke or flames.
3. Squeeze the handle to release the extinguishing agent.
4. Sweep the extinguisher from side to side until the fire appears to be out.
5. Once the fire is completely extinguished, discharge the fire extinguisher entirely and get it recharged, or replaced, immediately.

(See detailed instructions in the operation manual)

**WARNING**

Stay a safe distance from the fire and near an exit. Stay close to the floor to avoid heat and fumes. The chemical from the fire extinguisher will shoot at least 10 feet.

Establish a monthly fire extinguisher inspection program to ensure the extinguisher is fully charged and in proper working condition. Inspect the extinguisher prior to each time you operate or occupy the motor home.

After the fire is out, beware of flashback. Flashback occurs when flammable vapors from combustible liquids spread back to the ignition source and reignite the fire.

**NOTICE**

If the pointer on the pressure gauge is not in the operating range, immediately replace the extinguisher. Record the inspection date on the tag provided.

FUEL AND PROPANE SAFETY

**DANGER**

Turn off all pilot lights, appliances and appliance igniters before refueling motor home fuel or propane tanks. Failure to comply could result in death or serious injury.

Never use a flame to check for LP gas leaks.

**WARNING**

Do NOT place or store flammable liquids on board the motor home because fire or explosion may result. Failure to comply could result in serious injury or death.

Propane containers are equipped with safety valves that relieve excess pressure by discharging explosive gas into the atmosphere.

EMERGENCY ESCAPE EGRESS WINDOW

Use the side entry doors or rear emergency egress window exit (if equipped) as emergency escape routes. Escape routes are easily identified by the exit decals. Familiarize yourself with your egress window's location and the exit instruction for that window. When an emergency escape from a fire is necessary, already knowing your escape route will save your life.



NOTICE

Do NOT remove the window exit decal or the window exit instructions decal.

Emergency egress windows are to be used in emergency situations only, and are not designed for ventilation use. Window pane may detach from hinge if opened too far.

SECTION 3

WEIGHTS & TOWING

Reference Abbreviations	3-2
Weighing Your Loaded Vehicle	3-3
Car or Trailer Towing	3-5

REFERENCE ABBREVIATIONS

MANUFACTURE/CONVERSION DATE

The date on which the coach portion of your motor home was built.

GROSS VEHICLE WEIGHT RATING (GVWR)

The maximum permissible weight of this fully loaded motor home.

SLEEPING CAPACITY WEIGHT RATING (SCWR)

The manufacturer's designated number of sleeping positions multiplied by 154 lbs (70 Kgs).

OCCUPANT AND CARGO CARRYING CAPACITY (OCCC)

The value equal to the GVWR minus UVW and full LP Gas weight. In other words, OCCC is the amount of weight in occupants, cargo, water and trailer tongue weight that can be added to the motor home without exceeding the GVWR.

GROSS COMBINED WEIGHT RATING (GCWR)

The Gross Combined Weights Rating of the motor home, i.e, combined weight of the Motor home and any towed vehicle.

DESIGNATED SLEEPING CAPACITY

The manufacturer's designated number of sleeping positions.

GROSS AXLE WEIGHT RATING (GAWR)

The value specified as the load carrying capacity of a single axle system, as measured at the tire-ground interface.

TIRE SPECIFICATION

Recommended tires specification to meet handling, loading and safety requirements. Replacement tires must meet these specifications.

COLD TIRE INFLATION PRESSURE

Inflation pressures recommended (while cold) for the tires originally installed on your motor home. These tire pressure levels must be maintained to ensure proper handling, safety and fuel economy.

CARGO CARRYING CAPACITY(CCC) [CANADA ONLY]

Equal to GVWR minus the total of the following: UVW, full fresh (potable) water weight (including water heater), full LP-Gas weight and SCWR.

UNLOADED VEHICLE WEIGHT (UVW)

The weight of this motor home as manufactured at the factory with full fuel, engine oil and coolants.

MASS OF WASTE WATER TANKS

Total weight of the black and gray water tanks when filled to capacity.

VEHICLE IDENTIFICATION NUMBER (VIN)

This 17 digit number identifies the chassis on which the motor home is built.

TYPE

The National Highway Traffic Safety Association (NHTSA) designated usage classification for your Motor home. MPV signifies a Multi-purpose vehicle.

WEIGHING YOUR LOADED VEHICLE

When traveling on public roads you must ensure at all times, your vehicle is below the Gross Axle Weight Ratings (Front GAWR and Rear GAWR), the Gross Vehicle Weight Rating (GVWR), and if towing a trailer or car, within the gross combined weight rating (GCWR) of the chassis.



Traveling at weights higher than these ratings is dangerous and illegal.

IMPORTANT DEFINITIONS

Gross Axle Weight Ratings (Front and Rear) GAWR is the maximum weight that your loaded motor home can place either on the front or rear axles measured independently.

Gross Vehicle Weight Rating (GVWR) is the maximum weight of both axles added together (Please note that adding together the front and rear GAWRs does not equal the GVWR).

The Front GAWR, Rear GAWR, and GVWR is located on the chassis manufacturer provided decal, black and white sticker on the driver's door frame.

To check the weight of your fully loaded motor home, locate a commercial weighing scale that can weigh large trucks. Certified scales such as CAT are preferable as they have a system in place to ensure their measurement accuracy. In rural areas, most grain storage elevators have scales available but accuracy for lighter loads may not be as high as it is with guaranteed highway scales. Most scales will charge a nominal fee for weighing a vehicle.

LOADING BEFORE WEIGHING

Load your vehicle completely as if you were going on a long trip with everything you would carry, including food, clothing, bedding, lawn chairs, bikes, tools, etc., a full fuel tank, full propane tank, and a full tank of fresh water (if you typically travel with your water full) and holding tanks empty (if that is how you typically travel). Also have the driver and passengers sitting in the vehicle in the belted positions when the weights are taken.

WEIGHING (MOTOR HOME ONLY)

The basic procedure is to take three separate weights - front axle, whole vehicle, and rear axle. You will first drive only your front wheels onto the scale pad and measure, then drive ahead so that the whole vehicle is on the scale and record the weights, then finally pull off until only the rear wheels are on the scale and measure.

You will receive a ticket with these 3 weights which you can use to compare to the chassis specifications in the chassis owner's manual and on the sticker on the driver's door sill. If the scale cannot record the weight of the entire unit, simply add the front and rear measured axle weights together to get the loaded vehicle weight.

CALCULATING YOUR WEIGHT VS CAPACITIES

The total loaded weight of the motor home (front and rear axle measurements added together) must not exceed the Gross Vehicle Weight Rating (GVWR) specified on the Vehicle Certification Label. The front or rear axle weight should not exceed the corresponding Gross Axle Weight Ratings (GAWRs) specified on the vehicle certification label found on the driver's door frame (white decal with black printing).

SPECIAL NOTE: If you tow a vehicle or trailer or have other loads on the hitch receiver, these must also be counted against the Rear GAWR and subtracted from the rear axle cargo capacity. See next section for more detail. How you load your vehicle affects the front and rear axle weight and side to side weight distribution which can influence vehicle handling. By repositioning the cargo you travel with, you may be able to shift weight to a more lightly loaded axle or even out your side to side weight distribution. For safe operation you must never exceed the GVWR, front GAWR, or rear GAWR. Refer to your chassis owner's manual for more information on weighing your vehicle and allowable loading.

EXAMPLE: You take your Coach House Motor home to a certified scale and weigh each axle individually. The vehicle is loaded as you would normally travel with your typical number of passengers in the belted seats. Your fuel level is full, and your LP tank and water tank are full, your waste tanks are empty.

Question: How would I determine how much more cargo I can carry in my motor home?

Answer: On the driver's door, the vehicle identification decal has the following information depending on the chassis of your motor home. This is only an example:

- **Front Gross Axle Weight Rating (FGAWR) – 4410 Lbs**
- **Rear Gross Axle Weight Rating (RGAWR) – 7720 lbs**
- **Gross Vehicle Weight Rating (GVWR) – 11,030 lbs**

From weighing your unit at the scale your weight ticket says:

- **Front axle weight 3900 lbs**
- **Rear axle is 6800 lbs.**

The total of these two numbers is your loaded traveling weight of 10,700 lbs.

The maximum amount of extra cargo you can carry is determined by calculating:
GVWR minus the loaded traveling weight is **11,030 lbs – 10,700 lbs = 330 lbs**

But where the weight is located on your unit may affect your gross axle weight ratings.

The amount of extra cargo that can be carried on each axle is:

Front FGAWR – Weight measured on front axle **4410 lbs - 3900 lbs = 510 lbs**

Rear RGAWR minus Weight measured on rear axle **7720 lbs - 6800 lbs = 920 lbs**

It is important to understand that the front and rear gross axle ratings do not add up to the gross vehicle weight rating. Even though both of your axle loads might be within limits does not mean that the entire coach is within the GVWR specification.

CONCLUSION: There is enough carrying capacity on either axle to be able to carry the additional 330 lb. You could increase the amount of cargo carried by traveling with less water if you are near maximum weight limits. You could also relocate some of your cargo to shift weight to a lighter loaded axle.

CAR OR TRAILER TOWING

The factory installed towing hitch on your motor home has a maximum capacity as shown on the decal on your hitch. Do not assume your motor home can tow what the rating is on the hitch. The maximum allowable trailer weight and gross combined weight rating are published in your chassis owner's manual.

IMPORTANT DEFINITIONS

Found in Chassis owner's manual.

Gross Combined Weight Rating (GCWR) is the maximum weight of the loaded motor home (including passengers) and what you tow added together.

Maximum Trailer Weight Rating is the maximum towed trailer or car weight that the chassis manufacturer has determined is safe to tow.

Found on decal affixed to the hitch.

Hitch Capacity – Gross Trailer Weight is the maximum trailer weight.

Hitch Capacity – Tongue Weight is the maximum vertical weight your trailer can place on the ball of an 8" hitch extension.



Regardless of the hitch ratings, the maximum amount you can tow will be limited by either your GVWR, GAWR's, GCWR, or maximum trailer weight rating as stated by the chassis manufacturer.

You may not be able to tow the maximum trailer weight as stated in your manual depending on the options chosen on your unit, how you load your unit and how many passengers you have on board when you travel. When towing a trailer or vehicle, never exceed either the GVWR, the rear axle GAWR, the chassis GCWR, the hitch ratings or the maximum trailer weight rating.

The maximum trailer weight is GCWR (from the manufacturer) minus loaded vehicle weight (including passengers) as measured at a scale provided that this number is less than the horizontal tow rating of the hitch. This maximum can change depending on number of passengers, level of water, sewer or cargo on board. In general, if you want to tow more carry less.

The maximum trailer hitch vertical pin weight will usually be limited by how much weight the hitch transfers to the rear axle (RGAWR) of the motor home but could be limited by the GVWR or vertical pin rating of the hitch. A general rule of thumb is that for each pound added to a hitch (8" maximum extension from the face of the receiver), approximately 1.6 lbs is added to the rear axle due to the cantilever effect.

The only way to confirm you are within legal limits, is by weighing your “loaded and ready to travel” vehicle including your trailer at certified scales. Calculations are an excellent tool, but real measured weights are proof you are traveling legally. Be aware that hitch load can affect handling characteristics. The more weight on the hitch, the lighter the front end will feel at the steering wheel. Additionally, the farther the load is away from the face of the hitch receiver, the more load will be transferred to the rear axle.

When towing a vehicle behind your motor home, the tow bar should be level or pointing slightly upward towards the tow vehicle. When coupling the vehicle tow bar to the Factory Receiver Hitch using a “drop receiver” or a conventional “ball mount” (commonly referred to as a “stinger” or a “draw bar”), do not exceed a 4” drop, nor one that the centerline of the hitch pin to the centerline of the ball exceeds 8”.

Always provide lights on the towed vehicle by connecting to the 7-pin plug on the rear of the motor home. This plug will provide power to the lights for brakes, flashers, turn signals and running lights.

Question: How much trailer weight can I tow with the unit in the example in the towing section of this manual?

There are four important considerations to this question:

- ***The total weight of the loaded motor home and the trailer or car added together compared to the gross combined weight rating.***
- ***The tongue weight of the trailer on the vehicle and its affect on GVWR and rear GAWR***
- ***The total weight of the trailer being towed compared to the chassis maximum trailer weight specifications.***
- ***The maximum gross trailer weight and tongue weight ratings of the hitch installed on your unit.***

All of these specifications are related and the maximum trailer weight is the lessor of any of these 4 variables. Weight of the trailer – In the chassis manufacturer’s owner’s manual they state that the Gross Combined Weight Rating (GCWR) of your chassis.

Simply subtract loaded traveling vehicle weight from the GCWR and you have the maximum trailer weight. Be advised that as you add more cargo or accessories to your unit, the maximum trailer weight will decrease.

In this example GCWR minus Motor home Traveling Weight = Maximum Trailer weight.

Tongue Weight – Since the hitch receiver is behind the rear axle, every pound of hitch tongue weight added increases the rear axle weight by 1.6x due to the cantilever effect. To calculate maximum trailer weight, we need the gross combined weight rating (GCWR) from the chassis owner’s manual which is the maximum amount your loaded motor home and your trailer/car can weigh together. We know that there is “X” lbs amount of capacity left on the rear axle from the calculation above, but we can only add “X” lbs of extra cargo to the whole vehicle based on the maximum GVWR which was calculated above. Therefore, the maximum tongue weight would be “X” lbs divided by 1.6 for the cantilever effect.

Rating of the hitch – Different models may have different hitch ratings which is dependent on body configuration. If either the tongue load or maximum trailer weight exceed the hitch specifications, the hitch specifications would be the maximum allowed.

SUMMARY

Many factors must be considered when determining cargo capacity and maximum trailer tow weight. How much cargo you carry with you when you travel is an important factor in both calculations. Just because your owner’s manual or the hitch decal says you can tow a certain weight trailer, it does not mean you can do so legally.



It is the owner’s responsibility to ensure that all axle and gross vehicle weight, and trailer weights are always within the chassis and hitch specifications of your motor home.

SECTION 4

MOTOR HOME OPERATION

Motor home Preparation	4-2
Pre-trip Inspection	4-3
Occupancy	4-5
Seat and Shoulder Belts	4-6
Traveling	4-8
Severe Weather Information	4-11
Emergencies While Driving	4-12
Parking	4-15
Leveling Motor home	4-16
Refueling Vehicle	4-17
Door Locks	4-18
Entry Door Step	4-19
Slide-Out Room	4-20
Exterior Lighting	4-21
Main Awning	4-22
Power Sofa / Bed	4-23

MOTOR HOME PREPARATION

Before beginning an extended trip, ensure you are thoroughly familiar with your motor home's condition, components, features, appliances and limitations. Take ample time to read the operator's manual and the material in the your Information Kit, and ensure you understand the operation of all the components.

Adequate preparation is essential for an enjoyable and successful trip. Your motor home provides the freedom to do what you want, where you want and when you want. The time you spend getting to know your motor home will enhance your enjoyment, maximize your experience and contribute to a more successful trip.

AUXILIARY VEHICLE TOWING

If you are planning to tow another vehicle or a trailer with your motor home, contact your local department of transportation for towing information. It is the responsibility of the operator to ensure that motor home loading specifications and limits are not exceeded. Always weigh and reload if required. Keep all frame members level or the tow hitch angled slightly upward for the best results. Be familiar with and comply with all applicable laws and regulations.



CAUTION

For safe towing and vehicle handling, maintain proper motor home and trailer weight distribution. The total weight of the motor home and the towed vehicle must not exceed the GCVW rating as stated on the vehicle certification label.

EMERGENCY EQUIPMENT CHECKLIST

The following list describes the minimum amount of emergency equipment required, but additional items may be appropriate for your specific personal needs:

1. First aid kit
2. Emergency flares
3. Toolbox and tools
4. Plastic bucket
5. Tow rope or chain
6. Wheel blocks or jacks
7. Water hose
8. Electrical cord extension
9. Fire extinguisher
10. High visibility vest

PRE-TRIP INSPECTION

1. Ensure the motorhome and all of its components, devices, systems and subsystems are serviced and ready for travel.
2. Inspect wheel lugs for tightness. Examine tires for signs of damage and wear. Ensure that all tires are properly inflated. Also check all fluid levels including:
 - Engine/crankcase oil
 - Power steering/transmission fluid
 - Radiator recovery system
 - Battery electrolyte level
 - Windshield washer reservoir
 - Diesel exhaust fluid (DEF) [When applicable]
3. Check the oil level in the generator power plant (if installed). Refer to the generator instruction and maintenance manual located in your Information Kit for details on all pre-use requirements.
4. Consult the chassis manual in the Information Kit for a list of pre-trip inspection requirements.
5. Verify that all lights are in working order.
6. Check the engine compartment for wildlife.



NOTICE

Wildlife and pets like the warmth of the engine compartment and can become entangled in the moving engine components.

7. Sanitize and fill the fresh water tank if required. Turn off the water pump unless using water. Turn off the water pump if leaving the unit unattended for an extended period of time.
8. Start the refrigerator a day ahead of time so it will be cold for your trip.
9. Fill the LP gas tank to a maximum of 80% of its capacity. Be careful not to overfill the LP gas tank. An overfilled LP gas tank will cause the gas regulator to fail, and may result in problems with LP gas components. Turn off the LP gas valve control located in the utility center. Make sure all LP gas controls are turned off (furnace, stove top and refrigerator). Check for LP gas leaks regularly using soapy water.



DANGER

Turn off all appliances while refueling any motorhome or LP gas tanks. Do NOT smoke while refueling.

PRE-TRIP INSPECTION

10. Check that sewer connections are properly stored and all external compartments and filler openings are closed and/or locked.
11. Ensure the roof vent opens and closes.
12. Be sure that all doors are closed and latched with travel locks in place, and ensure all loose objects are secured including cabinet and refrigerator contents.
13. Deodorize the waste holding tank.
14. Check that all blocks and chocks are removed and stowed.
15. Check that there are no obstructions in the motorhome's pathway before moving. Ensure there is proper clearance between adjacent and overhead objects to prevent making contact.
16. Disconnect and stow the shoreline power cord. (Refer to details in this section)
17. Lock exterior compartment doors.
18. Check that the fire extinguisher is in good condition and fully charged. (Refer to the "Safety" section for details)

FINAL CHECK



CAUTION

Unsecured objects can become dangerous projectiles in a sudden maneuver or accident.

1. Secure all objects inside and out. Tie, latch or lock all loose objects as appropriate.
2. Securely close and lock all doors to minimize the chance of a door coming open in an accident.
3. Adjust all rear-view mirrors to provide the best rearward visibility.
4. Set the driver's seat to provide the desired leg to pedal spacing for your personal comfort.
5. Fasten seat-belts, position low on the torso, and ensure they are snug. All passengers must be in a seat that is equipped with a seatbelt. All pregnant riders should be in a seat equipped with a shoulder strap for maximum safety.
6. Do NOT carry any passengers unless they are in a seat that is equipped with a seat-belt and the seatbelt is properly fastened.

OCCUPANCY

MAXIMUM OCCUPANCY

The belted seating positions in your motorhome may be different than the stated sleeping capacity. You may use all the belted seating positions available in your motorhome, provided you stay within the GVWR and GAWR listed on your vehicle certification label.



All occupants must be in seats equipped with lap or shoulder harness seat-belts with the seat-belt fastened when the motorhome is in motion. Small children must always be placed in a certified child restraint system and secured with a seatbelt



All seat-belt retractors are equipped with locks that engage when the belt extends too quickly. Move the spade end of the seatbelt slowly and steadily across your body when fastening to prevent the lock from engaging. If the belt locks while extending, release the tension and allow it to retract fully. Then pull out to fasten.

EXTENDED OCCUPANCY

Your motorhome is designed for recreational and short term occupancy. In case of extended occupancy, there are a few things to keep in mind regarding humidity and condensation. Excessive moisture released inside the motorhome can cause water stains and mildew on the upholstery, wall materials and woodwork. Moisture condensing on the windows is an indication that the humidity inside your motorhome is too high.

The following procedures will help to reduce the moisture level inside your motorhome:

1. Open windows and vents. This will allow fresh air to flow through your motorhome and reduce moisture levels.
2. Reduce the amount of moisture released inside the motorhome. Run the bathroom fan when using the bathroom and turn on the roof vent fan while cooking to help remove excessive moisture from your motorhome. Do not hang wet towels or swim-wear inside the motorhome to dry.

SEAT AND SHOULDER BELTS

Every occupant must be seated in an approved seat with the seat-belt properly fastened whenever the motorhome is in motion. Accident statistics prove the importance of using seat-belts. Vehicle occupants not seated in an approved seat and restrained with a seat-belt are likely to suffer more serious injuries than those who are properly restrained.

LAP AND SHOULDER BELTS

The driver and passenger seats are equipped with a combination lap and shoulder belt 1 for maximum restraint.

LAP BELTS

The recliners, dinette or sofa may be equipped with lap belts if requested. Never allow occupants to travel in a seat that is not equipped with a lap or shoulder belt.

PREGNANCY AND SEAT BELTS

Pregnant occupants of the motorhome should wear the lap belts low on their torso and should position the shoulder strap diagonally across their chest. Do not position the shoulder strap against the neck. Wearing a seat or shoulder/lap belt properly will protect both the mother and the unborn child.

CHILD RESTRAINTS

Child restraint systems are legally required in many jurisdictions in North America. Statistics prove that children not secured with a certified and appropriately sized child restraint system experience more severe injuries than those who are properly restrained. The National Highway Traffic Safety Administration (and Canadian equivalent), mandates anchors and tethers for child restraint systems in passenger vehicles, but these NHTSA rules do NOT apply to your motorhome. Therefore, your motorhome is not equipped with any anchor or tether restraint system for use with child restraint seats. In evaluating and providing the safest conditions for your young passengers, you must take into account the following considerations:

1. Familiarize yourself with the laws and regulations of all states and provinces in which you will use the motorhome. Laws governing the transport of children and the use of child restraint and anchor systems vary in different jurisdictions.



CAUTION

Placing a child or child restraint system in a rear-facing or side-facing seat is not safe under any circumstances.

2. In accordance with applicable law, your motorhome is not equipped with any anchor or tether system on any of its forward facing seats.
3. Obtain a child restraint that is labeled as certified to comply with all applicable U.S. and Canadian laws, rules and regulations applicable to child car seat, harness, anchor and/or tethering systems before allowing any child to travel in your motorhome.
4. Ensure that any child restraint system you use conveniently and safely attaches to the structural elements of your motorhome and provides safety for a child every time it is used.
5. Ensure that your child restraint system is suitable and adequate for your child's age, weight and height. Check your child's restraint system instructions and labels to verify that it is suitable and adequate.
6. Carefully review the labels and instructions supplied with your child restraint system and correctly and appropriately install your child restraint system in accordance with the labels and instructions and all applicable laws and regulations.
7. If anchors or tethers are required for the safe or legal use of your child restraint system or for your child's age, weight and height, you may have a difficult time safely transporting a child in the motorhome, because no anchors or tethers are installed on your motorhome as manufactured.

DRIVER AND PASSENGER SEAT CONTROLS

Depending on the Coach House Motor Home Model purchased your base truck chassis will be made by Ford or Mercedes Benz. It is important to read their respective owner's manuals to best operate and effectively use them properly. The seating controls are designed to be used only in the manner outlined in the manual . With respect to seating it is wise to familiarize yourself with to following seat controls (if available) for your safety and comfort:

1. Seat Swivel Function
2. Lumbar Support
3. Back Rest Adjustment
4. Seat Height Adjustment
5. Seat Cushion Height Adjustment

TRAVELING

DRIVING CHARACTERISTICS

Refer to the chassis owner's manual for engine starting, operation and stopping instructions.

DRIVING CONTROLS

Your motorhome driver controls are similar to those of an automobile. Steering and braking controls are power assisted to help make driving as comfortable as possible. Your motorhome is much higher, wider and heavier than any automobile so the operator must anticipate and account for the differences.

GENERAL HANDLING

The motorhome power-to-weight ratio is lower than that of the average automobile. It is essential to compensate for slower acceleration when moving into traffic or when passing another vehicle. Allow extra room to corner and to change lanes. When going underneath a bridge or similar overhang, you must be aware of your maximum height. (Measurement must include the air conditioner plus 6 in. (152 mm). Height may vary depending on chassis, make, suspension, tire pressure, roof loads and air conditioner.)

HIGH WIND HANDLING

High winds or strong wind gusts may lead to unpredictable handling and motorhome control. When encountering high winds or strong wind gusts, proceed as follows:

- ***Slow down significantly so you can maintain control of your motorhome.***
- ***Find a safe place to pull off the road and take shelter.***
- ***Park your motorhome facing directly into the wind to minimize high wind buffeting.***

MOUNTAIN DRIVING

When driving in hilly or mountainous terrain, exercise safe driving techniques that match terrain conditions.

CLIMBING A HILL

The transmission of your motorhome is designed to automatically down-shift when required during long, uphill climbs. If the transmission frequently shifts up and down, select a lower gear for the duration of the climb to prevent repeated shifting. This will prevent unnecessary wear and tear on the transmission. Refer to your chassis owners manual for more information.

DESCENDING A HILL

Select a lower transmission gear when descending a hill to avoid prolonged brake applications. Under extreme conditions, prolonged brake applications could lead to excessive brake wear, overheating and failure causing you to lose control of the motorhome. Refer to your chassis owners manual for more information.



CAUTION

Extended brake applications can cause excessive wear, overheating and under extreme conditions, brake failure that could cause you to lose control of the motorhome.



NOTICE

A safe driving practice is to use the same lower gear position when descending a hill that you used while climbing the hill.

Carefully observe the engine temperature, especially during long climbs. If you notice overheating, pull off the road and allow the engine to fully cool before continuing. Refer to the chassis user's manual for instructions on filling the engine cooling system of your motorhome.

DRIVING SAFETY TIPS

1. When backing-up the motorhome, have a person stand to the rear on the driver's side to guide you.
2. Before departing on a trip, check your routes for height restrictions. Remember, some tunnels prohibit motorhomes with LP Gas systems.
3. While traveling, make sure all occupants correctly use their seat-belts.
4. While traveling, make sure all doors are closed and that cabinets, drawers and loose objects are secure.
5. Instruct your family about what to do in case of fire and periodically hold fire drills.
6. Maintain a properly charged fire extinguisher.
7. Ensure LP Gas and smoke detectors are unobstructed and in proper working order at all times.
8. Keep a well-stocked first aid kit on board the motorhome.
9. Check tires often while traveling. Make it a habit to check tire pressures before each trip and visually inspect each time you refuel.
10. If you have a cellular phone, carry it with you for emergencies.



DANGER

CELLULAR PHONE SAFETY TIPS

- *Do not drink and drive. Do not allow others to do so.*
- *Do not text and drive.*
- *Do not use a cell phone while driving.*
- *Always use a hands-free system while driving.*

TRAVEL TIP LIST

As you travel with your motorhome, you will learn a great deal from your own experiences. Share your experience with other motorhome owners and learn from them as well. Read RV, outdoor and camping magazines for camping and travel tips. The following basic suggestions also may make your travel and camping easier and more enjoyable:

1. Freezer doors are closed securely. Carefully open these doors after traveling. Contents may have shifted while traveling and may fall when you open the door.
2. Know the height and width of your motorhome, and allow for adequate clearance.
3. Use your mirrors while driving to determine whether you are crowding the center line or the outside edge of the highway. Remember, your motorhome requires a much different driving style than your family car.
4. When towing a vehicle, make sure the combined weight of the towed vehicle does not exceed the GCWR, GVWR, or GAWR as stated on the vehicle certification label located on the passenger door frame (US models only).
5. Check your route carefully before you travel. Some jurisdictions prohibit vehicles with LP Gas containers to drive through highway tunnels.
6. Fill your water tank with clean, fresh potable water only. Do not use a new hose to fill the tank as it may leave a taste of rubber or vinyl. Only use hoses rated for potable water.
7. Conserve water, especially when showering. The holding tanks have a limited capacity.
8. Dump sewage only at approved dumping sites.
9. Store all liquids in plastic containers with tight seals.
10. Watch the levels in your holding tanks. Dump regularly to avoid unnecessary buildup and potential odor. After dumping, add water to the black water tank to prevent solids from settling in the tank. Without adequate liquid in the black water tank, dumping can be difficult or impossible.
11. Be careful not to leave odor-causing food or materials in your motorhome for extended periods of time. Make sure wet clothing and towels are fully dried before storing.
12. Make sure your fire extinguisher is ready for use and that you anyone that comes with you knows how to operate it.

SEVERE WEATHER INFORMATION

As a motorhome traveler, you may want to explore new and out-of-the-way places. These recreational areas can be vulnerable to unusual and severe weather conditions. The following suggestions and safety precautions may help you in case you find yourself in severe weather situations.



NOTICE

All motorhome occupants must be familiar with these safety precautions and should be alert to changing weather.

1. Be alert. Thunderstorms and heavy rains can occur suddenly and unexpectedly. Frequently check weather reports for the area in which you are camping or traveling so you will not be caught unaware of sudden weather changes.
2. Remember the following terms:
 - Weather Watch - Severe weather may develop in your area.***
- Be prepared for an emergency.
 - Weather Warning - Severe weather is occurring or is imminent.***
- Immediately find a safe location.
3. When camping near a body of water, leave plenty of space and elevation between your motorhome and the water.
4. Avoid canyons or dry washes during threatening weather.
Prepare an alternate exit, and move to higher ground as soon as it starts raining.
5. If you get caught in a flash flood, do not attempt to move your vehicle. Abandon it, and return only after the water level has subsided. Never attempt to drive through any flooded area.
6. Comply with all warnings and instructions provided by local authorities.
7. Stock enough survival supplies for several days. This should include food, water, first aid supplies and necessary medications.
8. When you leave home, inform someone of your destination and your schedule.
Notify the same person if your plans change.

EMERGENCIES WHILE DRIVING

Your motorhome is designed with features that allow the driver and occupants to resolve some emergencies or failures while traveling. Review this section to become familiar with the recommended procedures to resolve these conditions or situations. Review this section with all new drivers and before each trip.

HAZARD WARNING LIGHTS

Your motorhome is equipped with a hazard warning light system. Both the front and rear turn signals flash in unison when the system is turned on. Refer to the chassis user's manual for additional details and location of the hazard warning lights.

Activate the hazard warning lights whenever the motorhome is stopped on the side of a roadway or near moving traffic. The hazard warning lights alert other motorists of a potential hazard and to take extra care. The system is designed so the lights continue flashing when the switch is on, even if the key is in the off position or removed from the ignition.

FLAT TIRE

If you have a flat tire while operating your motorhome, slow down gradually to prevent loss of control and pull to the shoulder or the side of the road. Stop on a level paved surface and engage the parking brake. Refer to the following steps to change the flat tire:

1. Turn on the hazard warning lights.
2. Place wheel chocks in front and rear of tire located on the opposite side of the flat tire.
3. Immediately contact a qualified roadside repair service, because your motorhome is not equipped with a spare tire.
4. If a roadside service is unavailable, inspect the flat tire to determine whether you can service or repair it.
5. If you can service or repair the flat tire, you must raise the motorhome using the jack.
6. Consult the chassis user's manual to locate the jack and to determine the proper jack placement locations on the chassis.
7. If the ground is soft or unstable, carefully move the motorhome to a safe location before attempting to lift with the jack.
8. Use a jacking board for stability on loose or soft ground.
9. Raise the motorhome with the jack according to the instructions in the chassis user's manual.
10. Never allow any portion of anyone's body to be under the vehicle at any time while raising or supporting the motorhome with the jack.
11. Before resuming travel with a new or repaired tire, ensure the lug nuts are tightened in the proper sequence and to the torque specified in the chassis user's manual. Use a torque wrench to ensure the specified torque is achieved. Recheck and re-torque the wheel lug nuts after 25 and 100 miles (40 and 160 km) of operation.

WHEN VEHICLE IS DISABLED

EMERGENCY STARTING

Do not push or tow the motorhome in an attempt to start it. The power train is not designed to transmit torque to turn the engine over for starting.



NOTICE

Attempting to pull or tow the motorhome to start may result in major drive train component failure or damage.

JUMP STARTING/BOOSTING

Refer to the chassis user's manual for instructions.

BREAK DOWN

If the motorhome breaks down on the roadway, pull off the road and stop, engage the parking brake, turn on the hazard warning lights and chock the wheels if you are on uneven or unstable ground. Call an approved towing service and provide it with the vehicle make, weight, length, width and height to ensure they dispatch an appropriately sized truck to tow your motorhome to a qualified repair facility.

OVERHEATING

If the engine overheats while driving, follow these steps:

1. Pull to the side of the road and stop immediately.
2. Shut off the engine.



WARNING

To avoid burns or other injury, allow coolant to cool before removing any cap from a radiator or coolant recovery tank.

3. Check coolant level in the coolant recovery tank. The coolant level should be between the "full" and "add" marks on the tank.
4. If the coolant level is low, proceed as follows:
 - **Check for visible leaks from the hose connections, radiator and water pump.**
 - **Make sure the serpentine or separate water pump belt is tight and the cooling fan is turning.**
 - **If coolant level is low, add coolant to the recovery tank as soon as possible.**
 - **If the coolant is leaking, the serpentine or separate water pump belt is loose or broken, or the red warning light stays on, do NOT start the engine until the problem is corrected.**
5. Once the temperature gauge returns to normal, resume driving and keep an eye on the gauge. Do NOT resume driving until the problem has been corrected and the temperature has returned to normal.

PARKING

You can stop and park your motorhome much like an automobile; however, always remember that the unit is longer, wider and higher than a typical automobile and requires more room and clearance.



NOTICE

Always set the parking brake and place wheel chocks in front and rear of wheels to prevent unexpected movement.

BACKING UP

USING MIRRORS

Large mirrors are mounted on both sides of your motorhome to provide rearward visibility for the driver. They do not provide visibility directly behind or on top (clearance) of the unit, however.

USING SPOTTERS

For best results, have another person help guide the driver while backing. The driver and spotter should agree to the meaning of hand signals before starting the backing process. The spotter should always be in a position that is visible to the driver while backing.



CAUTION

The rear view camera is only an aid. It cannot replace your own awareness of the immediate surroundings. You are responsible for safe parking. When parking and pulling away, make sure that there are no persons, animals or objects in the maneuvering area.

BACK-UP MONITORING SYSTEM

Your motorhome is equipped with a rear camera monitoring system. The rear camera view will automatically display on the front monitor or in-dash entertainment system when you shift the vehicle into reverse. For complete operating instructions, refer to the chassis or monitor user's manual.



CAUTION

Do NOT take your eyes off the road for extended periods of time or a crash causing injury or death could result. Do NOT give extended attention to the in-dash entertainment system while driving.

LEVELING MOTORHOME

Level the motorhome frame before using any of the appliances. The refrigerator is especially sensitive and must be level to function properly. Spend the necessary time to level your motorhome to ensure maximum enjoyment and reliability of your appliances. Select the area to park your vehicle as follows:

1. Inspect the area you want to park your motorhome. Select an area that has a firm, prepared surface. Most campgrounds provide this type of parking area for motorhomes.
2. Select an area that is level, or as close to level, as possible.
3. Use a level on the floor to determine the locations where it is necessary to place planks under tires in order to level the motorhome.
4. Level from side to side first, then from front to back. To raise one side of the motorhome, place planks in front of the low side tire, and drive the motorhome forward until the tires are resting on top of the planks.



CAUTION

Exercise care and caution when parking and leveling your motorhome. Make sure all pets and people, especially children, are clear of the motorhome until leveling is complete and the motorhome is stable.

FULLY AUTOMATIC LEVELING SYSTEM

Many of our models come standard with a automatic leveling system, some are optional. The hydraulic leveling jack control panel is located in the “Tower of Power” cabinet to the right of the coach entrance doorway. Refer to the detailed operating instructions in the owner’s manual before operating. HWH is used on all models for leveling except the Platinum III Ford 250 (Transit) which uses Bigfoot Leveling Systems.



IMPORTANT LEVELING SYSTEM NOTES



NOTICE

1. Always verify that the jacks are fully retracted and safe for travel before attempting to move the motorhome.
2. Always use the AUTO STORE or ALL RETRACT button to properly stow the leveling jacks.



CAUTION

Do not use the 4 point leveling system to change tires.

REFUELING VEHICLE



WARNING

Make sure all LP Gas tanks and appliances are shut off before refueling. Do not smoke when refueling. Keep flames, sparks and smoking materials away from fuel or flammable fumes.



CAUTION

Modern fuel systems may allow pressure to build up in the fuel tank during hot weather. Under certain conditions, small amounts of fuel may spray from the fuel filler tube when the fuel cap is removed quickly, creating a potential hazard.

FUEL TANK CAPACITY

Refer to the chassis user's manual for fuel tank capacities.

FUEL TYPES

Use only ultra-low sulfur diesel fuel on all Mercedes chassis products, or a minimum 87 octane fuel for Ford chassis products. Refer to the chassis user's manual for details.



NOTICE

Use the correct fuel type for the motorhome. Using incorrect fuel can be hazardous and can cause significant and costly damage.

FILLING THE TANK

Do NOT overfill the fuel tank. Fill only until the automatic shut-off valve on the fuel nozzle stops the flow of fuel. This allows for expansion of the fuel and vapor as the fuel warms and expands in the fuel tank.



NOTICE

Overfilling the fuel tank may cause damage to the fuel evaporative emission system.

DOOR LOCKS

Separate keys are required for the ignition switch installed in the chassis and motorhome door locks. The coach entrance door is equipped with two interior locks. The first lock secures the exterior and interior door handles, and the other lock is a door dead bolt lock.

LOCKING AND UNLOCKING PROCEDURES KEY FOB

Although the chassis ignition switch and the motorhome door locks may require the use of different keys, the motorhome entrance doors can be locked/unlocked with the Ford or Mercedes Sprinter key fob. Using the key fob press the lock button to lock all the entrance doors. Press the unlock button to unlock the driver's side door. Pressing unlock button twice within 2 seconds will unlock all doors (including the coach entrance door if equipped with the optional key fob entry feature.)

INSIDE THE MOTORHOME

Your motorhome can be locked/unlocked from the inside using the buttons located on the driver and passenger side doors. Press the button to unlock all entrance doors; press the same button to lock all the entrance doors.

Note: When the dead bolt lock is in the locked position on the side entrance door, it can only be opened manually from inside or with a key on the outside.

KEYS

Keep a record of all key code numbers and keep them in a safe place. Do NOT keep them in your motorhome. Key codes for the chassis can be obtained only through your local authorized Ford Transit or Mercedes Sprinter dealer.

The following keys are provided with your motorhome:

1. TRUCK - Ignition Key - Ford regular key, Ford Transit or Mercedes Sprinter key fob.
2. MOTOR HOME - Side Door Entry - Tri-Mark - Deadbolt (number is unique)
- Tri-Mark - Regular key - Key # 1141
3. BOXES - Southco - Key # E3-5-15
4. GAS / WATER/ BUMPER - Key # CH751 - (Same size key as Sewer key)
5. SEWER - Key # CH751 - (Same size key as Gas / Water key)
6. EXTERIOR SHOWER - XiaoBoShi - Key # 800

ENTRY DOOR STEP



The KwikEE Entry System is equipped with a magnetic interlock system that activates the lowering and raising of the entry door step when the magnetic field is broken or created between the door and chassis. When the door is opened, the field is broken and the step is lowered. When the door is closed, the field is completed and the step raises. In addition, the light on the underside of the step automatically illuminates when you open the coach door.

NOTE: The step light will remain illuminated for five minutes after extending the steps.



Ensure the entry door step has fully extended before stepping out of the motorhome.



The entry door step automatically retracts and the step light switches off when you close the coach entrance door and turn the vehicle ignition switch to the "ON" position.

STEP OVERRIDE SWITCH

If you would like the step to stay in the "open" position when you are parked, flip the "override" switch located on the main switch panel just inside your motorhome door to the right on the "Tower of Power".

NOTE: The vehicle ignition switch must be in the "OFF" position for the step override switch to work



SLIDE-OUT ROOM



Your motorhome may be equipped with an expandable slide-out room, which provides extra living area for the occupants. HWH Hydraulic Room Extensions (Slide-outs) are Standard Equipment on many models.

BEFORE OPERATING SLIDE-OUT

1. Ensure that the motorhome is properly leveled and supported with the stabilizing jacks if so equipped.
2. Level the motorhome as described in the “Leveling Motorhome” section.



NOTICE

If the motorhome is not properly leveled before extending the slide-out room, the slide-out mechanism could bind causing damage.

3. Make sure there is adequate space beside your motorhome for the slide-out room to fully extend.
4. Ensure the batteries are fully charged when operating the slide-out room controls.
5. To operate hydraulics it is preferred to have engine running and emergency brake set.
6. Review the owner’s manual instructions that you received at the time of delivery before operating the slide-out room.
6. Check the interior of the slide-out room to make sure there are no obstructions on the floor or leaning against the walls or nothing has fallen behind the slide trim.
7. Close all cabinet doors.
8. Check the exterior of the unit to ensure all baggage doors are closed and there are no obstructions.
9. Make sure all bystanders are clear of the area before operating the slide-out room controls.

To Extend: Level motor home and set parking brake before extending slide-out portion. Turn ignition key to accessory position, turn control panel key to ON position and push switch to extend. Turn off control panel and ignition switch and remove keys.

To Retract: Turn ignition to accessory position, turn control panel key to ON and push switch to retract. Turn off control panel and ignition switch and remove keys.



SLIDE-OUT TOPPER - AUTOMATIC AWNING



For those motorhomes that are equipped with an expandable slide-out, each slide-out is made equipped with a Dometic Automatic Awning slide-out topper. The slide-out topper will extend and retract automatically when the slide-out is in operation. This topper helps keep debris and water away from the top of the slide-out. Additionally this also helps reduce wear on its seals.

SERVICING ALL-WEATHER SEALS

Cracked or worn all-weather seals around the slide out room may allow dirt and moisture to enter your motorhome which could lead to premature interior wear. Inspect the all-weather seals in the spring and fall, and have them replaced if necessary. Extensive travel and use in severe weather conditions may cause more rapid deterioration of some components, especially all-weather seals. Have professional service personnel, adjust, maintain and replace the all-weather seals to extend the life and comfort of your slide out room.

EXTERIOR LIGHTING

ILLUMAGRIP ENTRY HANDLE

Entry handles installed by Coach House Motorhomes are illuminated by L.E.D. bulbs which are connected to the outside lighting circuits. These handles will light up when the porch/step light circuit is turned on. In addition to the entry handle light, the main extended awning has a light.



MAIN AWNING



Your Coach House Motorhome has been equipped with the Girard GG-750 series legless motorized awning. Electrical power allows the unit to automatically retract using power from the “house” batteries in the event of unforeseen inclement weather.

NOTE: Clean your awning with MILD SOAP and WATER only!

EXTENDING THE AWNING

1. Press the “OUT” button located on the “Tower of Power” on the right just inside the door to begin extending the awning.
2. At any point, you can press the “STOP”, to stop the awning at its current position.
3. To turn on the awning lights, press the awning light on.

RETRACTING THE AWNING

1. Press the “IN” button located on the passenger seat pillar to retract the awning fully.



NOTICE

The power awning will automatically retract when the motorhome ignition is turned on. The power awning is equipped with a safety feature preventing the awning from extending while the motorhome ignition is on.

Make sure your Battery Cutoff Switch is in the ON position any time the Electric Awning is deployed'. Damage to the Awning or Motorhome may occur if power is not available in the event of inclement weather.

AUTO-RETRACT FEATURE

Your awning is equipped with an auto-retract system that will automatically retract the awning in wind and rain conditions. The system works by sensing movement at the end of the awning, and will retract if a certain movement threshold is surpassed. This includes, but is not limited to: wind gusts, heavy rain, excessive rocking of the motorhome, etc. It is recommended to retract awning when you are away from your Coach or during the night.



CAUTION

Auto-retract systems provide protection against adverse elements; but no auto-retract system is a guarantee against severe or destructive weather; the effects of wind and rain on an awning are unpredictable and may cause severe damage to the awning and/or vehicle. If wind or extended periods of rain are expected, retract the awning.



DANGER

Keep all sources of heat and flame away from the awning canopy. Fabric is not fire-proof and can burn if left in contact with any flame or heat source.

POWER SOFA / BED (SLIDE-OUT OPTIONAL EQUIPMENT)

Power Sofa/Beds are made by Kustom Fit, a division of Villa Industries. The fabric used matches the driver and passenger chairs and has a durability rating to last a long life in your motorhome. The power sofa/bed has 4 functions:

- 1) Move sofa away from outer wall.
- 2) Convert sofa to bed.
- 3) Move bed toward outside wall to adjoin stationary cushion.
- 4) Convert bed to sofa & move toward outside wall.

You may operate the power sofa/bed with slide-out room extended or with room no extended.

NOTE: Do NOT Continue to hold the button down once the sofa has extended or retracted. You can cause damage to the gears with prolonged use.



SECTION 5

APPLIANCE AND EQUIPMENT

Refrigerator	5-2
Stove-top Burners	5-5
Microwave / Convection Oven	5-8
Exterior BBQ Connection	5-9
Solid Surface Counter Tops	5-10
HVAC: Furnace, AC, and Vents	5-12
Hardwood Cabinet Doors	5-17
Entertainment Systems	5-18

REFRIGERATOR

Appliances and equipment may vary according to your motorhome model, specifications and floor plan. Refer to the your owner's manual for operation and maintenance details relating to the specific appliances and equipment installed in your motorhome.



NOTICE

The motorhome **MUST** be completely level for the refrigerator to operate properly and safely.



CAUTION

Operating the refrigerator with the motorhome parked on un-level ground could result in permanent damage to the appliance. Parking and leveling the motorhome for comfortable living will usually place the refrigerator within satisfactory level limits. Use a level to ensure the motorhome is level.

Do not cover or obstruct exterior refrigerator vents!

If the refrigerator is unused for an extended period of time, make sure it is emptied, switched off, defrosted, cleaned and left with the door ajar. Use the travel latch to lock the door in the ajar position.

NOTE: Leaving the door slightly ajar allows air to circulate and prevents the build-up of odor or mold.

REFRIGERATOR OPERATING TIPS

1. Start the refrigerator at least 24 hours before loading it with food to allow sufficient time to cool.
2. Ensure the refrigerator is cold before placing items in it.
3. Allow items to cool before loading the refrigerator. Do not add warm or hot items.
4. Do not pack the refrigerator too full.
To operate efficiently, the refrigerator needs air to circulate.
5. Use smaller containers to store items and containers that seal tightly..
7. Place crumpled paper between items in the refrigerator to prevent them from rattling while driving.

EXTERIOR REFRIGERATOR VENTS

The exterior refrigerator compartment is accessible from an exterior vent , it allows access to the rear of the refrigerator for cleaning, inspection, maintenance and service. There is also a necessary roof vent for refrigerators that run off of the (LP) liquid propane gas system. Keep the compartment, and the exterior vents clean and free of debris in order to maintain efficient operation of the refrigerator.

2-WAY REFRIGERATOR - AC/LP ABSORPTION



Refer to the refrigerator owner’s manual for detailed operating instructions.

Refrigerator operates in any one of the following modes:

- 120 volt AC electric
- LP gas Absorption

NOTE: The refrigerator is self-starting in all operating modes.

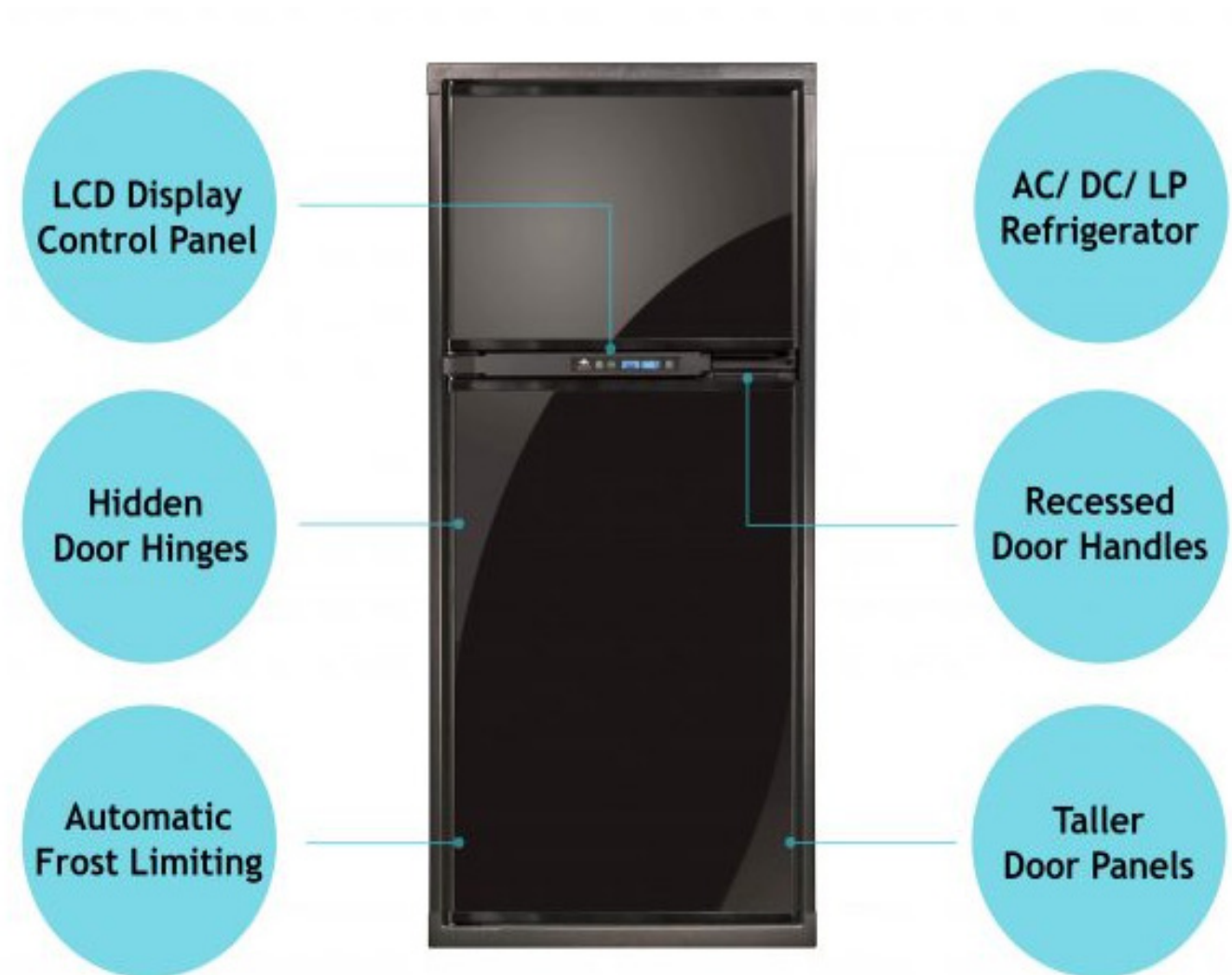

2-WAY REFRIGERATOR - AC/DC COMPRESSOR

NOVA KOOL

Refer to the refrigerator owner's manual for detailed operating instructions.

Refrigerator operates in any one of the following modes:

- 120 volt AC electric
- 12 volt DC Compressor

NOTE: The refrigerator is self-starting in all operating modes.



STOVE-TOP BURNERS

Depending on the motorhome model or options chosen the type of the galley stove-top is either an LP gas powered burner style (3 or 2 Burner) or an (1 Burner) 120 volt AC electric induction burner style. Refer to the owner's manual for detailed operating instructions.

NOTE: If the igniter fails to operate, check the 1 amp igniter fuse located in the cabinet below the stove top.

3-BURNER AND 2-BURNER



LIGHTING BURNERS

1. Ensure the LP gas valve switch is turned open.
2. Turn on the appropriate burner control knob.
2. Depress and hold the igniter switch until the burner lights.
3. Do not operate the stove top or the igniter while traveling or while refueling your motorhome. The burners may ignite fumes present during refueling.
4. Do not allow stove top burners to remain lit for an extended period of time without placing cookware above the flame.
5. Overheating the burner grates may cause damage.
6. Turn on the roof vent and open a window to ensure proper ventilation when operating the stove top.
7. Do not remove the warning label on the stove top lid (2-Burner units).
8. Do not operate burners with glass stove top lid closed (2-Burner units).



WARNING

Never use the stove top burners to heat the interior of your motorhome. Adhere to the warning labels in the cooking area. Always make sure you have adequate ventilation when operating the burners. Light the burner immediately after turning on the burner control knob to prevent a gas build-up. Excess gas can cause a flare-up when lit.

1-BURNER INDUCTION



Features Included: Built-in Safety Functions, Quick Touch Level Selection, Exact Temperature Settings, Timer Setting, and Two Year Limited Warranty*

TRUE INDUCTION 1 + 1 GAS COMBO COOKTOP MANUAL

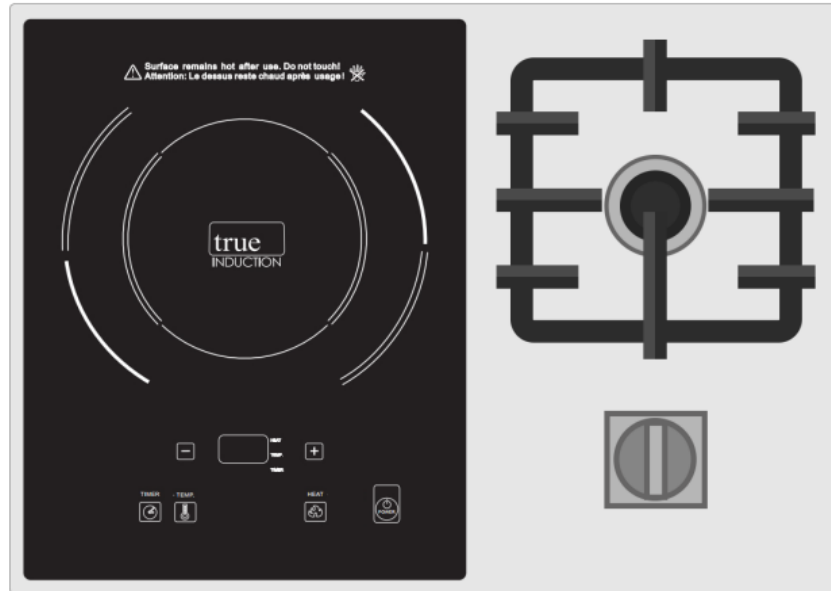

Important Safety Information

When using electrical appliances, basic safety precautions should always be followed. For the True Induction cooker, even with built-in safety features, it is essential to heed all precautions:

- When the unit is on, do not touch outside the control panel as the surface may contain residual heat.
- To protect against electric shock, do not immerse cord plugs or cooker in water (or other liquid substances).
- When using any electric appliance used around children, close supervision is strongly suggested.
- Do not operate any appliance with a damaged cord or plug, after a malfunction or if it has been damaged in any manner. Read the seller's guidelines for warranty repairs and returns.
- Do not cook on a broken or damaged cooktop as spillovers may penetrate the surface and create a risk of electric shock.
- To avoid potential injury, do not use accessory attachments which aren't recommended by the manufacturer.
- Do not let the cord dangle over the edge of the table or counter. Keep the cord away from hot surfaces.
- Do not place cooktop on or near: hot gas, electric burner or heated oven.
- To prevent accidents and achieve optimal fan ventilation, allow for sufficient space around the cooking area.
- Items with a magnetic field such as: radios, televisions, credit cards, cassette tapes etc., can affect the unit.

Important Safety Information Continued

- The power cord provided has been sized accordingly, however, with caution and care extension cords may be used.
 - a. The marked electrical rating should be at least as great as the electrical rating of the appliance.
 - b. The cord should be arranged so that it will not drape over the countertop or tabletop where it can be pulled on by children or tripped over.
- Do not use with empty pans/pots.
- Do not place metallic objects such as knives, forks, spoons, lids, cans or aluminum foil on the cooktop.
- To prevent accidents and achieve optimal ventilation, allow for sufficient space around the cooking area
- This appliance has a polarize plug (one blade is wider than the other). To reduce the risk of electric shock, the plug will fit on the outlet only one way. If the prongs do not fit fully, reverse the plug. If it still does not fit, contact the seller for warranty support; do not attempt to modify the plug in anyway.
- To properly turn off unit press the Power button.
- It is important to be aware that the unit's surface will remain hot for a short period of time after use.
- Disconnect power and allow to cool before performing any maintenance or repairs.
- Clean cooktop with caution - do not clean while unit is still hot, some cleaners produce steam or fumes if applied to a heated surface.
- Do not use cooktop for any other use then directed by the manufacturer.

Product Specifications

Power	1600 Watts
Voltage	120V/ 60 Hz
Temperature Range	150°F- 450°F (exact temp settings)
Level Selection	Selecting settings 1-10
Max Time	Set timer up to 150 minutes
Material	Glass ceramic top
Overall Measurements	24 3/8"W x 15"L
Base Measurements	23 5/8"W x 14 1/8"L x 3"H

MICROWAVE / CONVECTION OVEN



The microwave oven only operates on the 120 volt A/C system. This oven can be used as a Convection Oven, or a Microwave Oven. Refer to the microwave/convection oven manual for detailed operating, safety instructions, and helpful cooking hints specific to your unit.

Service Can be obtained at: 574-848-1118

Collins & Company, 17880 Commerce Drive, Bristol, Indiana 46507

OPERATING TIPS

1. Do not attempt to operate the oven with the door open. This may result in harmful exposure to microwave energy.
2. Do not defeat or tamper with the safety interlocks.
3. Do not place any object between the oven front face and the door or allow cleaner residue to accumulate on sealing surfaces.
4. Do not operate the oven if it is damaged. Do not operate the oven if there is damage to the door hinges, latches, seals or sealing surfaces. Do not operate the oven if the door does not close properly or is bent.
5. Do not adjust or repair the oven door. Have the unit serviced by qualified service personnel if necessary.
6. Do not operate the oven when empty.



EXTERIOR BBQ CONNECTION

Your motorhome is equipped with an exterior supply source to furnish LP Gas to your own barbecue (BBQ). The connection point is located on the passenger side typically just to the left or the right of the entry door.

OPERATING: EXTERIOR BBQ CONNECTION

1. Remove protective cover from the quick connect fitting.
2. Pull the collar of the quick connect fitting back and insert connecting hose to the quick connect fitting.

NOTE: Ensure collar is pulled forward once connecting hose is inserted.

3. Turn lever to supply LP Gas to your BBQ.

NOTE: LP Gas supplied to the exterior BBQ connection is regulated; therefore, use only a non-regulated BBQ.



Any exterior heat source (BBQ, space heaters, etc.) must be positioned away from the sidewall and directed away from the motorhome to prevent damage.

SOLID SURFACE COUNTER TOPS

Your Coach House Motor Home has Solid Surfaces on all counter tops. Refer to the following guidelines to help keep your Solid Surfaces in good condition for years of use.

Care and Use

Your solid surfaces countertops meet the demanding needs of today's surfacing applications. As a solid, non-porous surface, they can be maintained with minimum care to retain the original appearance. Because they can be repaired, they will still look and perform like a new installation, while other surfacing materials will often need to be replaced. With proper care your solid surfaces in your deluxe motorhome will stay looking like new.

Routine Care

Your countertops and all sinks and lavatories are finished with a matte/satin finish. Soapy water, ammonia-based cleaners or commercially available solid surface cleaners will remove most dirt and residue from this type of finish. Stubborn residue will require a little stronger cleaner. Follow the recommendations below to properly clean your solid surfaces.

Conventional Cleaning Techniques

- Washing with soap and water is usually sufficient to remove surface dirt or stains. Be sure to wipe surface completely dry.
- Ammonia based liquid cleaner (not window cleaner) may also be used. Always rinse surface thoroughly and wipe dry.
- Drying is an important step, preventing a build-up of soap film or cleaning residue, which can create the appearance of light scratches over time. In the event this occurs, apply a mild abrasive cleaner to a damp sponge or white Scotch Brite® pad and rub into the surface in a circular motion. When finished, rinse thoroughly to remove all cleaner, then wipe completely dry.
- Stubborn soap film or cleaning residue build-up is easily removed with abrasive cleanser and a white Scotch-Brite® pad or a sponge.
- For darker colors, a polish may be used to enhance the shine. For areas where there may be food contact, always use a polish formulated for food contact areas, such as Countertop Magic®. Where food contact is not a possibility, a simple furniture polish may be used. Always follow the manufacturer's instructions for using the polish and for safety concerns.

Cleaning Agents

Your countertops are unaffected by common household and commercial cleaners such as

- Powdered abrasive cleansers (like Comet®)
- Ammonia
- Strong detergents
- Oxalic acid solutions
- Dilute hydrochloric acid solutions
- Dilute trisodium phosphate solutions

Acid drain cleaners may cause surface damage and should not be used!

Cigarette Burns, Stubborn Stains

Unlike other surface materials stains or marks caused by cigarettes, alcohol, food, lipstick, hair dye, shoe polish, iodine, marking pens, etc. can be removed by using an abrasive cleanser and a green Scotch-Brite® pad.

This type of maintenance will not harm the surface, and will restore it to "like new" condition.

SOLID SURFACE REPAIRS

With use can come damage. Solid Surfaces are made to last and to be repaired. By following the information below in most cases any damage can be repaired to original appearance.

Repair of Damaged Surfaces

Solid surfaces can be repaired with no permanent damage. Tough to remove stains, fine scratches, and small cuts can be removed using standard repair techniques.

Professional repair:

You may wish to seek professional repair if the damage is severe.

Making your own repairs:

- To restore a matte finish - use 220 grit sandpaper followed by hard buffing with a green Scotch-Brite® pad in a circular motion.
- To restore a semi-gloss - use the 220 grit sandpaper, followed by 320 grit, followed by 400 grit. Then blend the finish in by using abrasive cleanser and a sponge or rag.
- If the damage is particularly deep, use a random orbital sander equipped with vacuum dust collection. Start with 120 grit sandpaper first, followed by 180-220 grit. After sanding, a uniform matte finish can be obtained by buffing with a green Scotch-Brite® buffing pad. For a semi-gloss, continue sanding with 320 followed by 400 grit. Then buff with a gray Scotch-Brite® pad.

The impact resistance of Corian® allows it to withstand harsh use without chipping, breaking, or cracking. However, if damaged due to extreme abuse, satisfactory repairs can often be made.

Preventing Damage

Avoid Strong Chemicals

Some chemicals are not compatible with your solid surface countertops. Avoid surface contact with:

- Strong chlorinated solvents
- Chloroform
- Ketones
- Methylene chloride (paint removers)
- Very strong acids such as concentrated sulfuric and hydrochloric acids
- Acid drain cleaners should not be used.

Surfaces exposed to these agents should be promptly flushed with water. Contact for even a short period of time can cause surface damage, spots, or staining. Follow the recommended repair procedures described above as needed to repair and/or restore the surface to its original condition. Severe damage caused by incompatible chemical contact will require professional repair.

While your solid surface countertops withstand heat better than most surface materials, do not place hot cookware directly on the surface. To avoid damage caused by excessive heat:

- Always use a trivet or hot pad under hot cookware
- Always use a trivet with minimum ¼" legs under small electrical appliances such as fryers and cookers

Your solid surface countertops can be scratched or gouged if used as a cutting or chopping surface for food preparation. Scratches can be repaired, but to avoid the problem, use of a cutting board is highly recommended.

HVAC SYSTEMS

LP GAS FURNACE



The furnace is controlled by the thermostat which also controls the air conditioning system. The furnace blower and automatic ignition are powered by the 12 volt DC system. As with all LP Gas appliances, all precautionary notes and labels should be carefully reviewed for maximum safety and comfort. Depending on the motorhome model the furnace is typically located under the galley or the bed platform.

WARNING

Before operating the thermostat, carefully read and follow the operating instructions in the LP Gas furnace owner's manual. Do NOT operate the furnace while the vehicle is moving.

CAUTION

Do not cover or obstruct exterior furnace vent.

LP GAS FURNACE OPERATING TIPS

1. Make sure the LP Gas valve switch or valve, located behind the exterior vent cover, is turned "ON".
2. Do not attempt to manually light the furnace. The furnace does not have a pilot light. It is ignited by a direct spark ignition system.
3. If the burner fails to light, check the LP Gas level at the system monitor panel to ensure there is LP Gas in your tank.
4. If there is LP Gas in the tank and the burner fails to ignite, verify that the LP Gas valve switch is in the "ON" position.
5. If there is LP Gas in the tank and the LP Gas valve switch is on, but the furnace still fails to light, turn off the thermostat, turn off the LP gas valve switch and contact your dealer or a local RV service center.

NOTICE

Ensure the thermostat fan is set to "AUTO" mode before turning on heat, otherwise the AC fan will continually run.

Truma Aventa comfort + soft start

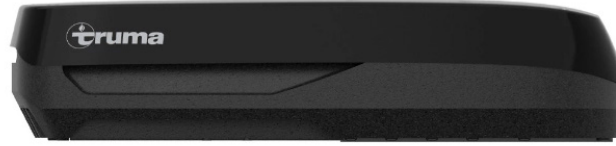

Truma has partnered with SoftStartUSA to make the Truma Aventa even more versatile. Integrating soft start technology into the already-efficient rooftop air conditioners allows us to significantly reduce the start-up power consumption of the Truma Aventa. This makes the Truma Aventa comfort + soft start ideal for use with solar panels, batteries, or generators. With the SoftStartRV pre-installed in these models, the Aventa comfort + soft start is able to maintain the consistent cooling and dehumidifying power RV owners have come to expect even when they are off-the-grid.

ROOF AIR CONDITIONER HEAT PUMP



The air conditioner heat pump is located in the center of the motor home on the roof with outlets in the ceiling. The air conditioner operates on the 120 volt A/C system and will operate only when the external power cord is connected to a power source or when the generator is operating. The roof air conditioner is controlled by the same thermostat that controls the furnace.

When the thermostat is switched to the “cool” position and the temperature is set below the ambient room temperature, the air conditioner will operate automatically. Air flow into the coach cabin can be controlled and directed by adjusting the vents.



CAUTION

Before operating the thermostat, carefully read and follow the operating instruction in the air conditioner owner's manual

HEAT PUMP

The air conditioner heat pump is designed to take the chill out of the air. To turn the heat pump on, turn the thermostat to “Heat Pump” mode to and set the temperature just above ambient room temperature. The heat pump will only work at temperatures above 41°F (5°C).



NOTICE

The air conditioner/heat pump operates only on 120 volt AC shoreline or generator power.

MAINTAINING THE AIR CONDITIONER HEAT PUMP

Clean or change the air conditioner filter at least every two weeks when the air conditioner is in operation. Do not operate the air conditioner without a filter.

NOTE: Refer to the air conditioner user's manual for detailed maintenance instructions.

CLEANING AND CHANGING FILTER

1. Release the filter cover by depressing the retainer clip.
2. Remove the filter and wash in warm soapy water.
3. Dry the filter thoroughly before reinstalling.
4. If the filter is excessively dirty, replace with a new filter.

COACH POWER ROOF VENT



The roof vent fans are located in the ceiling and are operated manually or by remote control. There are one (1) or two (2) vent roof fans in motorhome depending on the model. One is located towards the front near the gallery, and one is located towards the rear near the bathroom. Refer to the owner's manual for operating instructions.

Cranking up the fan covers can be done manually if necessary. The 12-volt DC system powers the fans. The fans have an automatic rain sensor, provides proper ventilation, comfortable temperature control and adequate air flow. Opening a window while operating the fan produces maximum air flow. Opening windows farthest away from the fan will provide the best air exchange. Use the vent fan in conjunction with an open window to provide fresh air flow.

Coach House does not use Maxxfan Vents with the 'Reverse' feature. For your safety, this eliminates the unlikely event that noxious fumes could permeate your motorhome while unattended, or while you are sleeping. Please disregard any reference to the 'Reverse' feature in literature from vents manufacturers.

VENT HOOD HEIGHT CONTROL

The rotary knob controls the height position of the vent hood. Turn the knob clockwise to pull the hood down and close it. Turn the knob counterclockwise to raise or open the hood.

CLEANING INSTRUCTIONS

1. Turn off the fan motor using the on/off switch.
2. Locate the thumb tab on the screen, and pull down to unsnap the screen.
3. Wash the screen and fan blade with a light, non-abrasive soap, rinse and dry.
4. Reinstall the screen by gently snapping it back into place.

CLEANING TIP

Once washed and dried, you may wipe or spray protectant onto the screen and blade (use only a water based protectant – do NOT use a petroleum based protectant). Buff to a high-gloss finish. This will minimize the amount of dust and dirt buildup.

ARRIVA VAN - POWER ROOF VENT

The Arriva Van vent is manual without a remote option.
Refer to the owner's manual for operating instructions.



BATHROOM ROOF VENT



 By DEXTER

NOTE: Not all floor plans have this fan. Bathroom roof vent fans are operated manually. Refer to the owner's manual for operating instructions. Rounded, plastic vent cover opens and closes with a simple push on the handle.

SIDE WINDOW VENTS

Turn the knob clockwise to open the window vent and counterclockwise to close the window vent.



NOTICE

When leaving the motorhome for extended periods, ensure all roof vents are fully closed to prevent rain from entering the coach interior.

DAY AND NIGHT WINDOW SHADES



Your coach is equipped with MCD American Solo and Duo Roller Shades. This system allows you to use the Day Shade or the Night Time Privacy Shade.

Refer to the owner's manual for adjusting, care and warranty instructions.

The spring tension should be accurately set in order to rewind the material gradually back into the fully rolled up position. Too much tension in the spring may cause damage to the shade material.

HARDWOOD CABINET DOORS



Limited Three Year Warranty for Coach House Owners

Congratulations on the purchase of a Coach House Luxury Motorhome! This warranty covers the wood cabinet doors found throughout your new motor home.

Wood is a material formed by nature not man and must be handled as such. Characteristics of wood are what give it its beauty and charm. Therefore, there may be some slight color variances due to the natural color variations in wood. The infinite variety in color, grain, and texture is what gives wood its natural character. Because of the differences among varying wood species, even within the same species, no two trees are alike. Climate, light, rainfall and minerals in the soil all create diverse and unique grain and color patterns in each piece of wood. These natural variations are not considered defects. We guarantee our doors free from defect in material and workmanship for three years from the purchase date of your Coach House model. Our warranty applies to the original motor home owner only.

Natural wood will expand and contract with climate and temperature conditions. Our doors are built to allow for proper wood movement. We will not be liable for damages done due to negligence or improper handling and/or cleaning of our doors.

We will guarantee against warping, twisting or swelling for doors that have been given responsible treatment and are within our minimum or maximum sizes. Warp or twist of 3/16" or less is not considered a defect.

Reasonable Treatment Required for Wood Doors

Doors should not be subjected to abnormal heat, cold, extreme humid or dry conditions or any sudden changes in temperature or humidity, and they should never be left open to the elements.

Replacement Policy

Contact your salesperson within one business week of receiving the defective materials. Your representative will arrange to inspect the doors. We may request the defective products be returned for inspection; if so please repackage the doors for shipment. We will have the materials returned to us at no charge to you. In order to minimize the inconvenience to you, Georgia Hardwoods will do our best to replace any defective products as soon as possible.

Contact Information

For Warranty Issues, please contact us at 800-992-6462 to initiate the claim process.

ENTERTAINMENT SYSTEMS

TV OPERATION

Refer to the TV owner's manual for detailed operating instructions.



Do NOT watch TV while driving. Do NOT take your eyes off the road for extended periods of time or a crash causing injury or death could result. Do NOT give extended attention to the in-dash navigation or entertainment system while driving.

SURROUND SOUND

(OPTIONAL)

The TV sound system is an optional purchase one-piece soundbar that brings noticeably better sound to all your favorite TV programs. It's engineered to help clearly reproduce everything from dialogue to details. And for even more clarity, its dialogue mode makes every word easier to hear.

This soundbar is so versatile you can place it almost anywhere. And with Bluetooth® connectivity, you can play your favorite music wireless through the speaker, too. Bluetooth technology built in for streaming music wireless from your phone or tablet.

One-piece soundbar delivers noticeably better sound than your TV alone. Dialogue mode to hear each word and detail clearly. One connection to your TV. Universal remote controls TV, bass, Bluetooth connections and more.

HIGH DEFINITION TELEVISION ANTENNA WITH WIFI BOOSTER



The Winegard Connect 2.0+ is a combination High Definition Television Antenna and WiFi Booster. It is mounted on the roof of your motorhome. This antenna will receive and supply HD signals over the air to your television, this enables WiFi signal amplification or 4G / LTE data service (with subscription). Refer to the owner's manual for instructions.

PUSH BUTTON AND INDICATOR LIGHT

1. LEFT Side push button and light indicates if power is on or not.
2. RIGHT Side push button and light indicates if WiFi Booster is on or not.



The new Connect 2.0 is an integrated system that works together for faster speeds and increased range from WiFi sources. Keep mobile devices, media players, and computers connected to WiFi with a reliable connection and expanded coverage. The Connect 4G2 links to nationwide 4G LTE for reliable, uninterrupted, in-motion and stationary coverage while traveling and offers the capability to swap SIM cards to add to new or existing data plans from other carriers!

See your Owner's Manual for the SIM password or call 1-800-320-9992 for support.

IN-MOTION SATELLITE ANTENNA (OPTIONAL)



RoadTrip® T4 In-motion Automatic Satellite TV Antenna

Winegard is excited to announce the launch of the new RoadTrip® T4 In-motion Automatic Antenna that works with DISH®, DIRECTV® and Bell TV™ programming.



Versatile - The RoadTrip T4 receives DISH, DIRECTV, or Bell TV programming for the ultimate in provider versatility.

Ultra Small - This sleek, compact unit is ultra lightweight, with the smallest footprint, requiring minimal roof space. Perfect for the on-the-go lifestyle!

Simple to Use - Easy one-button operation, 100% automatic with full in-motion tracking capability.

Quietest System with Improved Tracking and Durability - New motors and updated tracking algorithms reduce noise levels and improve tracking capabilities for quicker recovery when losses occur behind trees, bridges, etc.

Features and Benefits

Versatile

- Receives either DISH, DIRECTV or Bell TV for maximum provider versatility
- **1 TV** (one receiver)
 - Points to either satellites 110°, 119° or 129° (DISH), 101° or 119° (DIRECTV), or 91° or 82° (Bell TV)
 - Channel changes will prompt antenna to point to required orbital
- **2 TVs** (a receiver on each TV)
 - The system has two coaxial outputs to allow for two-receiver or dual-tuner DVR usage
 - Points to either 110°, 119° or 129° (DISH), 101° or 119° (DIRECTV), or 91° or 82° (Bell TV)

Ultra Small Antenna

- Dimensions: 14.3" diameter, 13.5" height
- Weight: 10 pounds
- Powered via power cable

Smaller than the RT Mission!



Fast Setup

- **Fully-automatic**
 - Automatically finds satellite orbital locations
 - Compact size requires less acquisition time

Quality

- **Winegard RoadTrip T4 has a 2 year warranty**
 - Backed by Winegard's two year parts, one year labor guarantee.

	Height	Width	Depth	Weight
RoadTrip T4				
unit	13.5"	14.3"	14.3"	10 lbs
pkg	16"	18.75"	15.75"	
RoadTrip Mission				
unit	12.9"	20"	20"	14 lbs
pkg	15.5"	22.25"	22.25"	

SECTION 6

ELECTRICAL SYSTEMS

Electrical Supply	6-2
Master Disconnect Switch	6-3
Power Converter	6-4
Circuit Breakers and Fuses	6-6
150 Amp Breakers	6-7
Auxiliary Start Over-Ride	6-7
GFCI Receptacles	6-8
Generator	6-9
Power Transfer Switch	6-10
12 Volt DC Power System	6-11
Lithium Battery System	6-12
Battery Maintenance	6-14
Inverter	6-18
Solar Battery Charger	6-19

ELECTRICAL SUPPLY

Your motorhome is equipped with two electrical systems that operate on separate voltages: an internal 12 volt DC system (coach batteries) and an external 120 volt AC system (shore power). The motorhome itself is designated as a 110 volt AC system, because it is single phase. The 120 volt source drops as low as 110 volts and is range bound between 120v-110v.

The 12 volt DC system draws power from the engine's battery and charging system while driving. When parked, the 12 volt DC system operates from the coach batteries, from shore power cable through the inverter / charger or from the generator through the inverter / charger.

The coach batteries charge automatically when the unit is connected to shore power or when the engine or generator is running. The 110 volt AC system operates either from the 120 volt AC generator installed in your motorhome or from the outside shore power cable connection. 120 volt inverted AC power is available in designated receptacles restricted to the inverter wattage limitations.



Do not connect the external power cord until you have confirmed the campground has the proper polarity and grounding. Improper grounding or reverse polarity may cause component damage or failure and/or personal injury or death.

SHORE POWER



To operate using shore power, connect the 120 volt AC power supply cable (stored in one of the exterior storage compartment) to the external receptacle located on the driver's side of the motorhome.

To connect the 30 amp power supply cable, lift up exterior lid. Insert the power cable into the socket by aligning the locking tab on the connector pin with the slot in the socket. Push the power cable in and until the spring loaded sides engage. Exterior lid can be lowered onto the cable to rest. To remove power cable both spring loaded sides need to be squeezed in, then pull the power cable out slowly. Then close the exterior lid.

MASTER DISCONNECT SWITCH

The 12 volt DC electrical supply to the coach portion of the motorhome is controlled by the battery disconnect switch located in the coach doorway.

The switch reduces the demand on the coach batteries to a limited residual draw when the motorhome is not in use or in short-term storage. Rotate the switch vertical to the 12 o'clock position to disconnect the batteries. Rotate the switch horizontal to 3 o'clock position to connect the batteries.

Coach House, Inc. recommends that the Master Disconnect Switch be turned to the "ON" position any time your motorhome is in use. Vital systems, including LPG and CO detectors will not function unless the Master Disconnect Switch is turned "ON".

Auxiliary batteries are being used when the switch is in the on position. Always turn the battery switch to the off position when the motor home is not being used to prevent the auxiliary batteries from being drained.

NOTE: Auxiliary batteries will charge from engine alternator or converter with battery switch in the "OFF" position.

NOTE: If coach is plugged in during non-use or storage, leave battery switch "OFF" to maintain auxiliary battery charge.



POWER CONVERTER



Your motorhome is equipped with a power center which is an all-in-one unit converter that supplies the motorhome with 110 volts AC (Alternating Current) breakers on the top and 12 volts DC (Direct Current) fuses on the side. The source of power can be from the:

- 1) Auxiliary “House” 12 volt batteries
- 2) 110 volt external power cord (Shore Power)
- 3) Generator



The converter is equipped with an automatic switch over relay to prevent both the generator and the external power cord from being connected to the converter at the same time. A separate Watt Inverter will power the electronics using only the “Coach” Batteries.

1. When either the external power cord or the generator is being used, both the 110 volt AC system and the 12 volt DC system will be activated inside the motorhome.
2. When neither of these is connected, the 12 volt auxiliary batteries will activate only the 12 volt DC system.



CAUTION

Whenever working on the electrical system, the system or circuit being worked on should be deactivated by disconnecting the power and/or throwing the main circuit breaker and safe procedures should be followed to prevent electrical shock. Any modifications made to the system should only be done by a professional to assure compliance with the codes and to assure safe installation practices.

POWER DISTRIBUTION

CONVERTER = 110V AC POWER INTO 12V DC POWVER

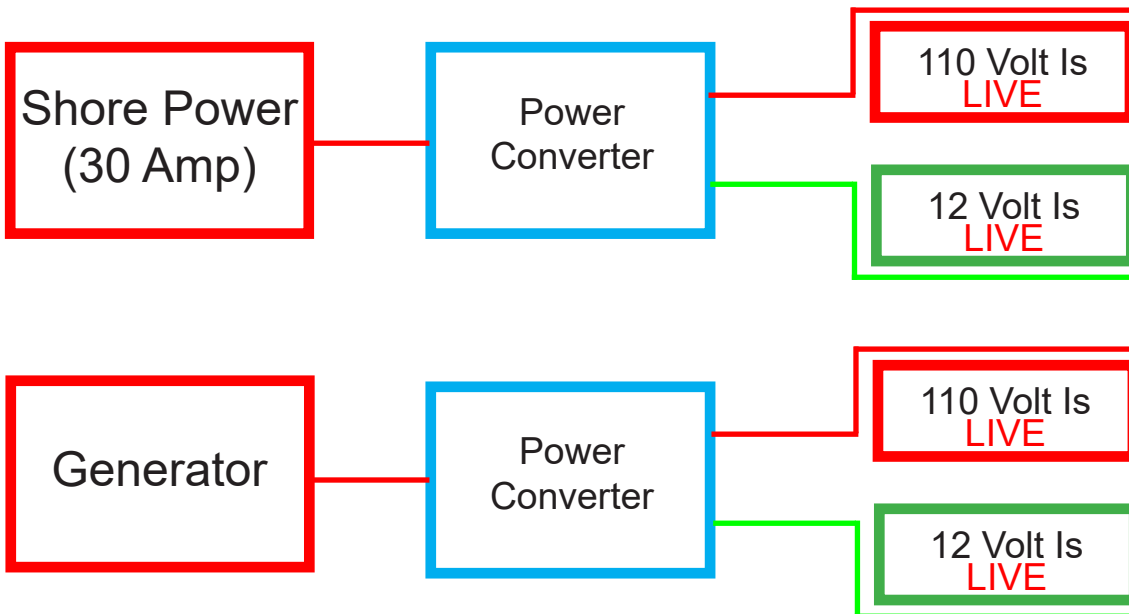

INVERTER = 12V DC POWER INTO 110V AC POWER

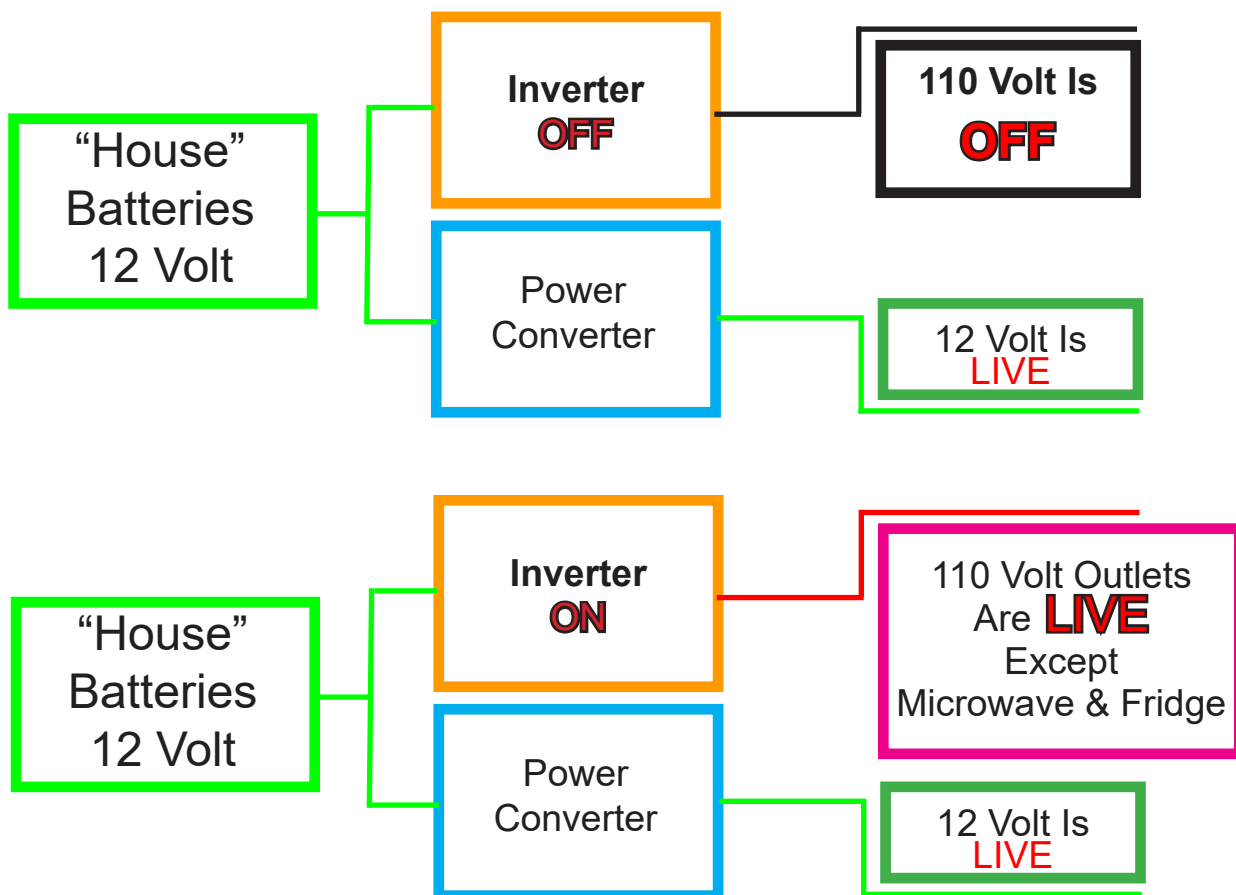

CIRCUIT BREAKERS AND FUSES

The converter door can be opened with a “push” touch and the circuit breakers and fuses can be located. The 110 volt AC breakers are located on the right with the first breaker on the left being the MAIN POWER, and the remaining breakers for the circuits as labeled on the door. The 12 volt DC fuses are the automotive push in type links and are located on the left side. The top two breakers are for system use, and do not feed the motorhome. The 12 volt DC circuits are labeled on the door.

110 VOLT AC CIRCUIT BREAKERS

The circuit breaker panel protects all 110 volt AC equipment and components in the motorhome from overload, a short in the wiring or a short in the component itself. In the event of an overload, the circuit breaker cuts off the flow of electricity in the particular affected circuit of the system and helps prevent damage or fire. If a circuit breaker “trips,” allow a brief cool down period of 30–90 seconds, then reset the breaker by turning it “OFF” and then “ON.” If a circuit breaker “trips” repeatedly, the circuit is overloaded or there may be a short in the wiring or in the equipment, and both should be checked and serviced by qualified service personnel. Refer to the control panel user’s manual for further details.

NOTE: There is a single 30 amp main circuit breaker which protects the entire AC electrical system. Check the main breaker if the entire electrical system will not function on shore power or generator.



CAUTION

If a breaker trips more than twice, leave the breaker off and have a qualified technician inspect it.

12 VOLT DC FUSES

Each 12 volt DC system circuit is protected by a dedicated fuse. When a fuse blows, shut off all appliances or lights on the affected circuit and replace the fuse with a new one of the same amperage.



WARNING

Fuse rating for each dedicated circuit is determined by the use and character of the equipment on that circuit.

Only replace fuses with the same amperage rated fuse. Failure to do so could result in fire.

150 AMP BREAKERS

There are 150 amp breakers located in every Coach House Motorhome. These breakers protect the electrical system from “back-feed” between the chassis and “house” batteries. It is rare that these breakers would trip, but in the case of a total power failure to your unit, this would be a possible safeguard which might have tripped. Push in the **RED** button (**CIRCLE** or **SQUARE**), or flip the switch to reset the breaker depending on their location.

FORD E-450 MOTORHOME - LOCATION

1. **RED CIRCLE** 150 amp breaker is located on the “Tower of Power” or just inside the coach entry door.
2. 150 amp breaker switch is located under the hood near the chassis battery
3. 150 amp breaker switch is located in the coach battery box

FORD TRANSIT- LOCATION

1. **RED CIRCLE** 150 amp breaker is located on the “Tower of Power” or just inside the coach entry door.
2. Two additional-150 amp breaker switches are located in the coach battery box

MERCEDES SPRINTER AND VAN -LOCATION

1. Two **RED SQUARE** -150 amp breaker are located in the passenger seat base

AUXILLIARY START OVER-RIDE

In the event that your engine battery does not have the power to start your engine, your motorhome is equipped with an Auxiliary Start Over-Ride Switch which will “tie” the house batteries to the engine battery to give an extra “boost” of power to start your motorhome engine.

OVER-RIDE OPERATION

1. Push the **RED SQUARE** breaker switch and
2. **HOLD IT DOWN** while starting your vehicle with the key

FORD MOTORHOMES - LOCATION

Over-Ride Switch is located on the dash panel just above your left knee when sitting in the driver’s seat.

MERCEDES MOTORHOMES - LOCATION

Over-Ride Switch is located on the driver seat base when sitting in the driver’s seat.

GFCI RECEPTACLES

GROUND FAULT CIRCUIT INTERRUPTER

A GFCI receptacle is different from conventional receptacles. In the event of a ground fault, a GFCI will trip and quickly stop the flow of electricity to prevent serious injury. All Coach House motor homes have GFCI receptacles in the bathroom and galley sink area. Exact locations vary by floor plan. See the GFCI user's manual for more information.

Various outlets in the motor home, particularly those near sinks and water supplies, are connected to a GFCI breaker. A GFCI detects electrical current that is traveling along an unintended path and automatically stops the current to reduce the risk of electrical shock and fire. If a GFCI breaker trips, unplug all the appliances on that circuit and reset the breaker in the breaker panel.

Plugging a Ground Circuit Interrupter (GFCI) into another GFCI can cause unnecessary tripping. This happens because GFCIs are designed to detect even small imbalances in the electrical current, and having two GFCIs in series can make the system more sensitive to these imbalances. When an appliance is plugged into a GFCI outlet that is already protected by a GFCI breaker, the two devices might interpret the same ground fault differently, leading to nuisance tripping. To avoid this, it's generally recommended to use only one GFCI in a circuit for proper protection and to reduce the likelihood of false trips.

NOTE: If a GFCI trips repeatedly there is likely a significant fault in that circuit. Have the faulty circuit and the GFCI investigated and repaired by a qualified technician before using it again.



CAUTION

The GFCI will not completely eliminate the risk of electrical shock. Small children or persons with heart conditions should be extra cautious because electrical shock could cause burns or cause the heart to stop even when a GFCI is present.

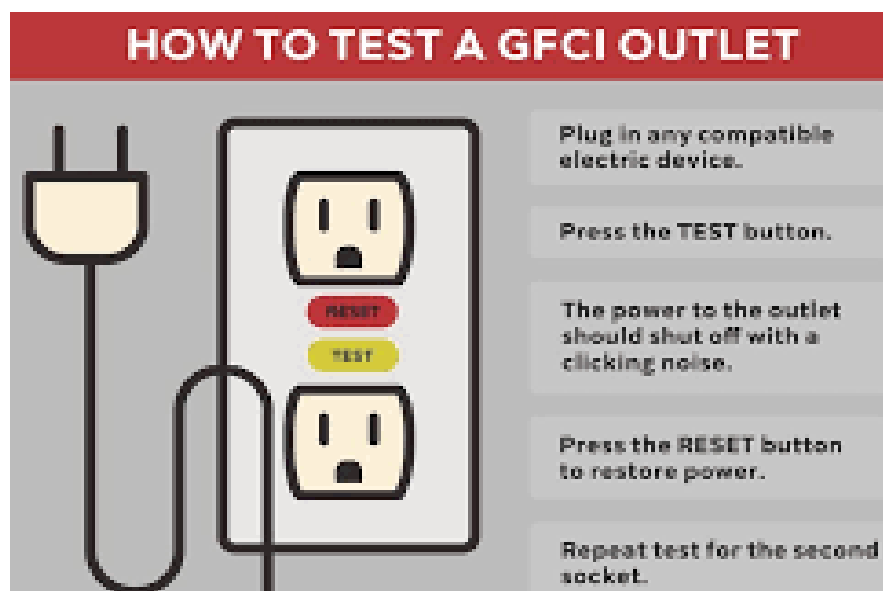

GENERATOR



The generator is located below the coach floor in a location which varies depending on the floor plan. The instruction manual supplied with the generator should be carefully reviewed. Care should be taken not to exceed the capacity of the generator to prevent any possible damage to the generator unit. If necessary, the generator can also be operated at the generator itself.

MERCEDES MODELS

Use 3.6 KW ONAN (Propane) Micro-quiet Generator

FORD MODELS

Use 4.0 KW ONAN (Gasoline) Generators or RVMP

NOTE: Ford Chassis Generators feed directly from your fuel tank. No special fuel fill is needed to power your generator. **Cummins Generators will not operate if your gasoline fuel tank is less than 1/4 full.** This feature will ensure that your vehicle has sufficient reserve fuel available for driving.



NOTICE

1. The generator starter draws power from the coach batteries, so the chassis ignition switch does not have to be on for the generator to operate.
2. There is a breaker located on the side of the generator cover to protect the generator from an overload. If there is a power outage, be sure to check this breaker, resolve any problems and reset.
3. The generator should be run a minimum of two hours a month.
4. Be sure to check the generator oil reservoir on a regular basis.

POWER TRANSFER SWITCH



AUTOMATIC SWITCH OVER

Starting the generator will automatically switch power from 120 volt AC shore power to generator power.

BUILT-IN DELAY

An automatic 20–30 second delay feature prevents the generator from starting while under load. This delay allows the generator to have the required amount of warm-up time before transferring power. This switch automatically transfers power from 120 volt AC shore power to generator power and prevents damage to any circuitry if shore power and the generator are inadvertently connected and operated simultaneously.



Always verify that appliances are turned off before starting or stopping the generator. Do NOT start the generator while it is under load. Ensuring all appliances are in the off position will help prolong the life of the appliances.

SURGE GUARD

Built into the power transfer switch is a surge guard. This Energy Management System (EMS) is self monitoring, no external monitor is given because of this self monitoring design. When shore power is connected it passes through the EMS surge protection device to protect the wiring.

- Do not exceed the rating on the EMS for any reason. These devices are designed to be reduced down to 120V/15A and maintain full protection.
- Do not modify the EMS in any way, as this will void the warranty, compromise protection and could result in possible shock and/or a fire hazard.
- It is important to always check the pedestal power outlet for charring. Charring indicates the AC receptacle is providing a weak connection. Should this condition exists DO NOT USE as it could result in possible melting of the RV power plug.
- All AC power extension cords in conjunction with your EMS unit should be rated 10 gauge for 120V, 30A systems and rated for outdoor use to reduce the risk of electrical shock. We recommend the length not to exceed 30'. Small gauge cable has higher resistance and can result in voltage loss or an electrical fire.
- Whenever servicing or installing the EMS, or any other AC powered device, make sure AC power is disconnected.

12 VOLT DC POWER SYSTEM

The 12 volt DC power system in your motorhome consists of the following two distinct, but interconnected, battery systems. One is the chassis battery the other is the coach battery.

CHASSIS BATTERY

The chassis battery operates the vehicle starter, vehicle accessories and all vehicle controls on the instrument console, such as the heater fans, exterior lights, horn, speed control, windshield wipers, etc. Disconnect the chassis battery cable when parking the motorhome for an extended period of time. Refer to the chassis operator's manual for the chassis battery quick disconnect location (if applicable).

CHASSIS BATTERY LOCATION

See the chassis owners manual for the location of the chassis battery. A 150 amp fuse located on the side of the chassis battery, protects 12 volt DC coach power system.



Disconnecting the battery cables from the chassis battery can clear the engine/transmission logic modules. These modules will automatically re-calibrate when you reconnect the battery and start the engine.

LITHIUM BATTERY SYSTEM IN YOUR RV

Welcome to your new Coach House equipped with a state-of-the-art lithium battery system. This manual provides important information regarding the use and maintenance of your lithium batteries, DC to DC charger, converter, and inverter. Proper understanding and care of these components will ensure a safe and efficient power management system for your RV.

Lithium Batteries

Your RV is equipped with advanced lithium batteries designed to provide reliable and efficient power. Lithium batteries offer several advantages over traditional lead-acid batteries, including higher energy density, longer lifespan, and lighter weight. Here are some points to remember:

- **Charging:** Lithium batteries should be charged using a compatible charger that is specifically designed for lithium battery technology. Overcharging or using an incompatible charger can damage the batteries and reduce their lifespan.
- **Maintenance:** Lithium batteries require minimal maintenance. Regularly check the battery terminals for any signs of corrosion and ensure they are securely.
- **Storage:** If the RV is not being used for an extended period, store the lithium batteries in a cool, dry place and charge them to approximately 50% capacity to prolong their life.

DC to DC Charger

The DC to DC charger is a critical component that ensures your lithium batteries are efficiently charged while driving. It regulates the power from the vehicle's alternator to the lithium batteries, providing a stable and optimized charging current.

- **Operation:** The DC to DC charger operates automatically when the vehicle is running. It monitors the battery status and adjusts the charging rate accordingly.
- **Troubleshooting:** If you notice any issues with the charging process, refer to the troubleshooting section of the DC to DC charger manual or contact customer support.

Converter

The converter in your RV transforms AC power from shore power or a generator into DC power to charge the batteries and run 12V appliances. It ensures a steady supply of power to your RV's electrical system.

- **Usage:** When connected to shore power or a generator, the converter will automatically charge your batteries and supply power to your DC appliances.
- **Maintenance:** Periodically check the converter for dust and debris to ensure proper ventilation. Clean as necessary to prevent overheating.
- **Safety:** Always follow the manufacturer's safety instructions when using the converter. Avoid overloading the converter to prevent damage.

Inverter

The inverter converts DC power from the batteries into AC power, allowing you to run household appliances while off-grid. This component is essential for a seamless power experience in your RV.

- **Capacity:** Ensure the inverter's capacity matches the power requirements of your appliances. Overloading the inverter can cause it to shut down or damage the connected devices.
- **Installation:** Proper installation is crucial for safe and efficient operation. Follow the manufacturer's installation guidelines or seek professional assistance if necessary.
- **Operation:** The inverter is typically operated via a control panel. Familiarize yourself with the panel's functions and monitor the inverter's performance during use.

Safety Precautions

- **Ventilation:** Ensure all components, especially the lithium batteries, have adequate ventilation to prevent overheating.
- **Fire Safety:** Have a fire extinguisher rated for electrical fires readily accessible in your RV.
- **Emergency:** In case of an emergency, disconnect the power supply to prevent further damage or hazards.

By following these guidelines and regularly maintaining your lithium battery system, DC to DC charger, converter, and inverter, you can enjoy a reliable and efficient power system in your RV. If you have any questions or need further assistance, please refer to the detailed manuals provided with each component or contact customer support team.

Happy Travels and enjoy your adventures with the confidence of a robust power system.

BATTERY MAINTENANCE

ENGINE BATTERY

Please refer to your Chassis Owner's Manual to correctly maintain your engine battery for recommended engine battery maintenance. The engine (chassis) battery of the motor home is also charged from the power converter. The engine battery should be periodically checked and maintained. Automotive batteries store chemicals that react and convert chemical energy into electrical energy.

COACH BATTERY

The coach batteries or auxiliary batteries are charged either by:

- 1) The Alternator of the motor home while driving**
- 2) The Power Converter when external 120 Volt AC power is connected**
- 3) The Generator**

Care should be taken to prevent the auxiliary batteries from being totally discharged by making sure that all of the lights, fans, and appliances are turned off when the motor home is not in use. Whenever the motor home is not used for a period of time, the 120 Volt power cord should be plugged in once a month for 8 to 12 hours to bring up the charge on the auxiliary batteries.

The master 12 Volt electrical switch (found to the left or right immediately upon entering the main motor home door) can be On or OFF for the converter charger to charge the auxiliary batteries. Refer to the converter power center instruction sheet for further information. A totally discharged battery will not normally recharge as quickly, or in the same manner as a low battery. Professional help should be used when attempting to charge a totally discharged battery.

The engine (chassis) battery of the motor home is charged from the alternator. The engine battery should be periodically checked and maintained. Refer to the Chassis Owner's Manual for recommended engine battery maintenance. Automotive batteries store chemicals that react and convert chemical energy into electrical energy.

BATTERY PROBLEMS

Several conditions can destroy the battery's function including sulfation and freezing. Sulfation occurs when lead sulfate crystallizes and deposits on the negative plates inside the battery. This condition is caused when a battery is deprived of a full charge for an extended period of time (30 days or more, especially during warm weather).

If sulfation occurs, you will have to replace the battery. Freezing can discharge, damage or destroy a battery. Batteries must be maintained at a nearly fully-charged condition to prevent the liquid electrolyte inside the battery from freezing.

BATTERY STORAGE

Batteries have a “life” which is determined by the number of charging/discharging “cycles”. When your system is not in use, proper care should be taken to extend the battery life by following these simple procedures:

SHORT TERM STORAGE

- 1) Turn off the Interior Battery Switch (Located inside the Motorhome Entry Door to the right).
- 2) Ensure that all current drains have been eliminated. (Turn off all appliances)

LONG TERM STORAGE

Proper long-term storage for your RV’s lithium batteries is crucial for maintaining their health and extending their lifespan. Follow these guidelines to ensure your batteries remain in optimal condition during periods of inactivity.

Preparation for Storage:

1. Turn off interior battery switch (located inside the motorhome entry door)
2. Disconnect the engine battery
3. **Charge to 50% Capacity**
 - Before storing your lithium batteries, charge them to approximately 50% of their total capacity. Storing batteries at this charge level helps prevent over-discharge and maximizes stress on the battery cell.
4. **Disconnect from RV Electrical System:**
 - Ensure the batteries are disconnected from the RV’s electrical system to prevent any parasitic drain that could discharge the batteries over time.
5. **Clean the Battery Terminals:**
 - Clean the battery terminals and connections to remove any dirt or corrosion. This will ensure a good connection when the batteries are reconnected after storage.

Storage Environment

1. **Temperature control:**
 - Store the batteries in a cool, dry place. The ideal storage temperature for lithium batteries is between 40 F (4 C) and 80 F (27 C). Avoid exposing the batteries to extreme temperatures, as this can negatively impact their performance and lifespan.
2. **Humidity Control:**
 - Keep the storage area dry and free from excessive humidity. Moisture can lead to corrosion and other issues that could damage the batteries.
3. **Avoid Direct Sunlight:**
 - Store the batteries away from direct sunlight or any other heat sources that could cause the batteries to overheat.

Monitoring During Storage

1. **Periodic Voltage Check:**
 - Every 3 to 6 months, check the voltage of the stored batteries. Ensure they remain around the 50% charge level. If the voltage drops significantly, recharge the batteries to the recommended storage level.

2. Inspection for Damage:

- Regularly inspect the batteries for any signs of physical damage, such as swelling, cracks, or leaks. If you notice any damage, do not use the batteries and contact the manufacturer for guidance.

Recommissioning After Storage

1. Gradual Recharging:

- When you are ready to use the batteries again, gradually recharge them to full capacity. Avoid rapid charging immediately after storage to reduce stress on the battery cells.

2. Reconnect to RV Electrical System:

- After recharging, reconnect the batteries to your RV's electrical system, ensuring all connections are secure and free from corrosion.

3. Perform a System Check:

- Conduct a thorough check of your RV's electrical system, including the DC to DC charger, converter, and inverter, to ensure everything is functioning correctly before hitting the road.

Additional Tips

1. Manufacturer Guidelines:

- Always refer to the specific guidelines provided by the battery manufacturer for storage and maintenance. Different lithium battery brands many have unique requirements.

2. Record Keeping:

- Keep a record of the storage conditions, voltage checks, and any maintenance performed. This can help you track the health of your batteries over time and identify any potential issues early.

By following these best practices for long-term storage, you can ensure your lithium RV batteries remain in excellent condition and ready for use when you resume your travels.



ADDITIONAL BATTERY MAINTENANCE SUGGESTIONS

Remove rings, metal watchbands and other metal jewelry before working around a battery. Use caution when using metal tools. If the tool contacts the battery terminals or the metal connected to them a short circuit could result.

1. Ensure batteries are securely fastened in the proper position.
2. Make sure battery clamps are tight and free from corrosion.

3. Keep the batteries and terminals clean and tight. Dirt accumulation can prevent sufficient current from flowing through the cables, and can permit current to flow between the terminals causing the batteries to discharge.
4. For AGM batteries, clean the battery with a solution of baking soda and water to neutralize any acid present then flush with clean water. Foaming around terminals or on top of the battery is normal during the cleaning process.

NOTE: Do NOT allow any baking soda solution to get into the battery. This can neutralize the battery acid.

5. Dry the cables and terminals before reinstalling them. Do NOT apply grease to the metal surfaces inside the cable terminals to prevent corrosion. Grease is an insulator and will prevent the flow of electricity. Use a plastic ignition spray to protect the terminals after you have cleaned and reinstalled them.

NOTE: When removing, replacing, boosting or charging the batteries, ensure the red positive (+) cable terminals are connected to the positive (+) posts and the black negative (-) cable terminals are connected to the negative (-) posts.

6. If installing batteries or booster/charger cables, attach the red positive (+) cable terminals first then attach the black negative (-) cable terminals.
7. If removing batteries or booster/charger cables, remove the black negative (-) cable terminals first then remove the red positive (+) cable terminals.
8. Do NOT attempt to recharge frozen batteries.
9. If using a battery quick-charge unit, disconnect the cables from the batteries.

NOTE: A battery quick-charge unit would be equivalent to a boost using booster cables from another vehicle but is not a battery tender or intelligent battery charging system.



Do NOT attempt to start the engine using a battery quick-charge unit.

10. If you do not have maintenance-free batteries, check the battery fluid level and fill with distilled water if necessary. Follow manufacturers guideline for fill height. Do not overfill.
11. Have the specific gravity of the battery fluid checked during regular motorhome service and maintenance.

INVERTER xantrex™

Smart choice for power™

Coach House Motorhomes uses a Xantrex Pure Sine Wave Inverter. The inverters are standard on all units. Inverters change 12V DC power stored in batteries into 120V AC power used in household appliances. The inverter can supply 16.7A AC at full capacity.

The watt inverter DOES NOT CHARGE. The inverter will supply 110 volt power to the electronic components (Television, DVD player, optional satellite receivers and the electrical outlets when you are not hooked up to shore power or running the generator. These devices will drain your “house” batteries if in use for an extended period of time.

The Xantrex Remote Panel is a complex computer control and monitor device, and is used on all models and floorplans. If any modifications are made to the battery bank, it may be necessary to change some internal settings. Please refer to the inverter owner’s manual for setting or contact the manufacturer. The Xantrex Remote Panel controls the invert features of the inverter.



NOTICE

The invert feature needs to be manually reset after a power outage. Even if the inverter feature is turned ON and the battery disconnect switch has been turned off, the inverter will need to be powered up and switched ON manually the next time it is turned on.

Please be aware that the inverters create a standby current drain even when your equipment is turned off. To ensure battery life, turn the inverter function OFF when not in use.

The inverter is not intended for appliances that consume more than the specified inverter wattage. Exceeding the specified wattage could result in damage to the appliance or the inverter. Extended use of the inverter-powered receptacles will drain your batteries.

The inverter remote control panel is factory configured for the specific inverter and battery installed in your motorhome. If modifications are made to the battery bank, it may be necessary to reconfigure the remote. Have the inverter and controls serviced by authorized personnel only.



CAUTION

Before performing any service, disconnect the inverter from power sources. Disconnect battery (12V DC) and shore power (120V AC). Inverter should only be serviced by a qualified technician.

SOLAR BATTERY CHARGER



Your motorhome is equipped with a 200 watt solar power kit. The solar power unit continuously charges the coach batteries to maintain the optimal charge, so long as sunlight is available. Refer to the solar panel and solar controller manual for detailed operating instructions.

The solar charger will charge the auxiliary batteries with the master 12 Volt switch in the “on” or “off” position. A Charge Controller will optimize the charging rate and cut off the charging current when the batteries are fully charged. Optimal charging will be obtained in direct sunlight.



The solar power unit is intended to charge the coach batteries only. It does not generate enough power to run the motorhome’s electrical system.

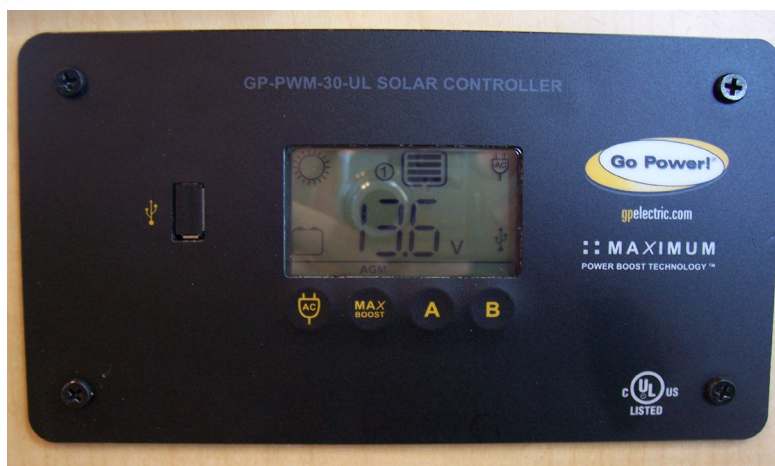

SECTION 7

WATER AND PLUMBING SYSTEM

Water Supply	7-2
Filling and Draining Water System	7-3
Water Pump / Gravity Fill	7-4
Sanitizing: Potable Water System	7-6
Tank Monitor	7-6
Waste Water Systems	7-7
Water Heater	7-10
Fresh Water Toilets	7-11
Showers	7-12

WATER SUPPLY

CLEAN WATER = WHITE PLUMBING CONNECTIONS

Your motorhome is designed with fresh water, gray water and black water systems and the associated plumbing to handle all of the water and waste water requirements. Review this section carefully to understand each system and how they function together. The following two sources may supply fresh water to your motorhome:

- **Fresh water tank - located under a bunk or cabinet in your motorhome (location varies according to floor plan)**
- **City water - a connection that supplies water to your motorhome through a hose located in the driver-side rear utility compartment.**

FRESH WATER SYSTEM

The fresh water tank system built into your motorhome provides full service similar to the system used in your home. A 12 volt DC self-priming pump draws water from the fresh water storage tank to all the cold water faucets and the water heater. An automatic pressure switch, located inside the water pump, maintains positive line pressure. The CH751 key is used to access the fresh water fill cap.

CITY WATER SYSTEM

The city water source supplies your motorhome's water system with water at pressure of the external source when the water pump is switched off. Simply connect the water hose to the city water connection located in the the driver-side rear utility compartment.



NOTICE

After connecting to the external water supply, open the faucets in your motorhome slowly and cautiously. Air trapped in the line can cause the water to splash into the sink. Drape a washcloth over the faucet to prevent excessive splashing.

Make sure that you close the water selector valve to use city water. Open the selector valve to fill fresh water tank only, otherwise close the selector valve when not in use.

Always turn off the water pump switch if leaving the motorhome unattended for an extended period of time and when driving to prevent excessive damage and battery discharge in the event of a leak.



CAUTION

Do not leave the coach unattended when filling with pressurized supply. Damage to tank may occur.

FILLING AND DRAINING WATER SYSTEM

CONNECTING THE EXTERNAL WATER SUPPLY

1. Make sure to turn off the water pump.
2. Attach a potable water hose to the city water connection.
3. Turn the water fill selector valve to the city water.
4. Turn on the city water supply.

DISCONNECTING THE CITY WATER SUPPLY

1. Turn off the city water supply.
2. Relieve the water pressure in the line by opening a faucet in the motorhome.
3. Disconnect the hose from the city water connection.
4. Replace the protective plug over the city water connection.

FILLING THE FRESH WATER TANK FROM CITY WATER CONNECTION

1. Remove fresh water fill cap to relieve system pressure from the system.
2. Connect the water hose to the city water connection.
3. Turn the water fill selector valve to water tank fill.
4. Turn on the city water supply.
5. Monitor the fresh water tank level.
6. Once the fresh water level reads full on the display, turn off the city water supply.
7. Turn the water selector valve to the city water position.
8. Turn on the water pump switch.
9. Slowly open the cold water tap until the water runs smoothly. Repeat with the hot water taps.
10. Put fresh water fill cap back on securely.

FROM POTABLE WATER SUPPLY

When a city water supply connection is not available:

1. Fill a suitable water container with potable water.
2. Remove fresh water fill cap to relieve system pressure from the system.
3. Fill fresh water tank.
4. Monitor the fresh water tank level.
5. Once the fresh water level reads full on the display, stop filling.
6. Put fresh water fill cap back on securely.

DRAINING THE FRESH WATER SYSTEM

Open the fresh water tank drain valve located near the fresh water tank near the water pump. The drain valve is located internally but the drain hose is routed outside through the floor. Open all faucets and low point drain located in utility compartment on the rear drivers side.

DRAINING THE HOT AND COLD WATER SYSTEMS

1. Disconnect the city water supply if connected.
2. Turn off the water pump switch.
3. Open all coach faucets.
4. Open the exterior shower faucets, lower spray nozzle to the ground open and spray empty.
5. Open all drain valves: fresh water, city water, the the hot and cold lines.

WATER PUMP / GRAVITY FILL



Refer to the Water Pump Owner's Manual for maintenance and use. The water pump should not be used when the motorhome is connected to city water. The motorhome has a potable water tank with a 12-volt DC demand pump connected to the system. The demand pump is controlled from the Control Panel. The pump should only be turned on when water is needed from the potable holding tank. Do NOT operate the pump dry or when there is no water in the potable water tank.

Drain valves are supplied on the potable water tank and in the water system near the pump to allow draining the system to prevent freezing.

NOTE: The water pump has a filter located on its side and must be checked and cleaned occasionally.

NOTE: When winterizing, the pump must be drained.

The potable fresh water water-fill is located on the side of the motor home behind the labeled door. The potable fresh water tank can also be filled from city water pressure. Open the selector valve to fill fresh (potable) water tank - turn off when tank is full. The location of the valve (on all models) is inside exterior utility door - drivers side behind rear wheel.



WATER PUMP TROUBLESHOOTING

The water pump is designed to supply on-demand water from the fresh water tank to the various water and plumbing systems in your motorhome. When a faucet is opened, the pump comes on automatically and pressurizes the various water lines.

WATER PUMP INITIAL STARTUP

1. Make sure all drain valves are closed.
2. Turn off the water pump switch.
3. Fill the water tank.
4. Open the hot and cold faucets.
5. Turn on the water pump switch.
6. Close each faucet (hot and cold) as soon as water flows steadily through the faucet.
7. Verify that the water pump stops after closing all faucets.
8. The water pump is now ready for automatic operation.

IF THE WATER PUMP WILL NOT PRIME

1. Make sure there is water in the tank.
2. Make sure the chassis battery is not discharged.
3. Make sure there are no kinks or obstructions in the inlet hose.
4. Make sure all inlet fittings and connections are air tight.
5. Make sure water selector valve in the exterior utility center is closed.
6. Check for clogged screens.

IF WATER PRESSURE DROPS

1. Check faucets and connections for leaks.
2. Make sure faucet aerators and filters are clean.
3. Make sure there is water in the tank.
4. Make sure the chassis battery is not discharged.
5. Make sure the water pump screen is not clogged.

IF PUMP RUNS WHEN THERE IS NO DEMAND FOR WATER

1. Make sure all faucets and fixtures are shut off and are not leaking.
2. Check all lines for leaks.
3. Make sure there is water in the tank.
4. Make sure no air is trapped in the system.
5. Make sure water selector valve in the exterior utility center is closed.



NOTICE

Periodically check the screen on the intake side of the water pump. Clean or replace the screen at least annually to ensure proper water pressure. Unscrew the filter bowl to access the screen remove the screen, and clean with fresh water. Replace in reverse order, ensuring the filter bowl is securely tightened. Refer to the water pump owner's manual for further related information.

SANITIZING: POTABLE WATER SYSTEM

WARNING

Potable water only. Sanitize, flush, and drain water tank before using. See below for complete instructions, care, and maintenance information. Failure to maintain tank may result in death or serious injury.

To assure complete sanitation of your potable water system, the following procedures are recommended for a new system, or for one that has not been used for a period of time, and for one which may have become contaminated.

1. Prepare a chlorine solution using:
 - A. One-quarter (1/4) cup of household bleach (2% sodium hypochlorite solution) added to B
 - B. One (1) gallon of water
2. With tank empty pour two (2) gallons of solution into the tank.
3. Complete filling of tank with fresh water.
4. Operate all faucets to release trapped air.
5. Pressurize the entire system with a pump, if available, and turn off pump.
6. Allow mixture to stand for three (3) hours.
7. Drain system and flush with fresh potable water.
8. To remove excessive chlorine taste or odor (which may remain).
Prepare a solution of:
 - A. One (1) quart vinegar to into B
 - B. Five (5) gallons of water and pour into tank.
9. Allow solution to agitate in tank by vehicle motion (several days if possible)
10. Drain tank and flush with fresh potable water.

TANK MONITOR

Refer to the See Level II Tank Monitor Owner's Manual for information and use. Your Coach House Motorhome comes equipped with a tank monitor to monitor your Fresh Water Tank, Gray Water Tank, and Black Water Tank levels. In addition it also monitors the Coach Battery and the LP Tank levels.



WASTE WATER SYSTEMS

BLACK PLUMBING CONNECTIONS

GRAY WATER HOLDING TANK = LIQUID WASTE

The drainage from the kitchen sink and shower pan is collected in a separate gray water holding tank. This tank has its own dump valve which ties into the same termination valve outlet as the waste holding tank.



NOTICE

Overfilling the gray water holding tank could cause the overflow to back up through the shower drain.

BLACK WATER HOLDING TANK = BODY WASTE

The black water holding tank collects all the waste from the toilet and bathroom sink. Before using your waste holding tank, deodorize it by adding one gallon of water and a commercial holding tank deodorizer into the toilet.



NOTICE

Overfilling the black water holding tank could cause the overflow to back up through the toilet.

DUMPING HOLDING TANKS

The connection for draining the holding tanks are located on the left side of the motor home. To drain the system, connect one end of an appropriate drain hose to the drain connection and the other end to a proper dump station. After the connections are made, opening the dump valve or valves can dump the system. The valves are located under the motor home on the driver's side rear and are labeled.

DUMP BLACK WASTE 1st - DUMP GRAY WASTE 2nd

1. Connect the sewer hose to the tank outlet located on the rear driver's side under-body.
2. Pull the black water tank dump valve handle to empty the black water tank. Leave the dump valve open and pull gray water dump valve handle to empty gray water tank. Close both valves when you no longer hear or feel waste water flowing through the sewer hose.
3. Remove, rinse and store hose.



NOTICE

Do not leave the valve on the black water tank open when connected to a drain, The liquid will drain out leaving the solids to accumulate becoming very difficult to remove.

Do not dump the black water tank until it is over one-half full.

BLACK WATER WASTE TANK SYSTEM FLUSH

The motorhome is equipped with a black water waste tank flushing system to improve draining and to reduce odor. To flush the tank, follow these steps:

1. Drain the black water holding tank and keep connected to dump hose system.
2. Remove the protective cap and connect the city water supply hose to the connector located in the exterior utility center.
3. Open the black water tank dump valve if it was closed.



NOTICE

Always open the black water tank dump valve before turning on the water supply.

4. Turn on the city water supply to thoroughly flush the system by spraying the interior of the black water holding tank.
5. Continue to leave drain valve open until flushed.
6. Turn off the city water supply, disconnect the city water supply hose and install the protective cap on the connector.
7. Close the black water tank dump valve.

NOTE: The black water tank flush line incorporates a non-return valve, which prevents black water contamination of the city water supply hose. If city water does not flow when connected as above, the non-return valve may be defective and require replacement. The non-return valve is located behind various wall panels depending on coach floor plan.

WASTE WATER HOLDING TANK - DO'S AND DON'TS

1. **DO** keep your holding tank clean using a cleaning agent approved for recreational vehicle sanitation systems.
2. **DO** add a special deodorizer or chemical additive approved for recreational vehicle sanitation systems to reduce odor and help break down waste.
3. **DO** keep both tank dump valves closed to enable the tanks to fill before emptying.
4. **DO** keep both tank dump valves closed and the drain cap tightly in place while traveling.
5. **DO** use soft, single-ply, non-dyed, biodegradable toilet tissue.
6. **DO** open the shower room vent to provide fresh air and reduce excessive moisture buildup.
7. **DO** keep all roof vents and windows closed when traveling to prevent odors caused by negative pressure.
8. **DON'T** put facial tissues, paper, permanent (automotive) antifreeze, sanitary napkins or household toilet cleansers in your holding tank.
9. **DON'T** put anything solid in your holding tank that could scratch or damage the plastic components.
10. **DON'T** use any mechanical drain cleaning devices unless the in-line trap has been removed.

USING ON-SITE SEWER HOOK-UPS

When staying at a campsite where sewer hook-up is available, the sewer hose may be attached and left in place for the duration of the stay. **Do NOT leave the dump valves open!** Open the dump valves only when the tanks are full, or when you are ready to leave the campsite. This will keep solid wastes in suspension allowing them to drain with the liquids when you open the valves. If the valves are left open, the liquid waste will drain, leaving the solids to collect on the floor of the black water holding tank. If solids collect, close the valves, fill the tank with water and drive a few miles. You can also help clean the tank by adding 1/4 cup of dish detergent to the water. The motion of the vehicle and the water will help dislodge the wastes and allow the tank to drain in the usual manner.

WATER HEATER



ON DEMAND - LP GAS POWERED

WATER HEATER OPERATION

The water heater is accessible from outside the coach. The water heater is designed to operate on LP gas only and is a tank-less pressure operating system which provides hot water on demand. Refer to water heater operating instructions for detailed instructions and detailed winterizing procedures. Do not cover or obstruct exterior water heater vent.

Verify city water supply is turned on or the fresh water tank fill level is adequate for use.

1. Remove the water heater exterior cover by turning the latch counter-clockwise.
2. Ensure the water heater pressure relief valve is closed.
3. Turn the propane “shut off” switch to O, which will allow the interior switch to work as well.
4. Press the water heater to either Eco or Comfort ON position.
5. Ensure the water heater valves are in the instructed positions for normal operation.

OPERATING MODES

ECO

The appliance is now running in energy saving mode.

- Water temperature at the outlet is approximately 120 °F (49 °C).
- Prevention of freezing by using LP gas. Temperature is automatically kept above 41 °F (5 °C).
- During operation, the yellow status LED is lit.

COMFORT

The appliance is now running in a mode that provides rapid availability of hot water.

- Water temperature at the outlet is approximately 120 °F (49 °C).
- Stand-by heat. The temperature is automatically kept above 102 °F (39 °C).
- During operation, the yellow status LED is lit.

OFF

Stand-by. The appliance is not running in any operating mode. The yellow status LED is off.

ANTIFREEZE

Prevention of freezing using 12 VDC electricity:

Operating mode with installed electric antifreeze kit (available as an accessory) and appliance switched on. Temperature is automatically kept above 41 °F (5 °C).

- During operation, the yellow status LED is lit.

CLEAN

Used to decalcify the hot water heater.

- During operation for safety reasons, after 30 seconds the decalcification process cannot be stopped until the system has been rinsed in accordance with the instructions.

FRESH WATER TOILET



The toilet in your motorhome operates much like a residential toilet except it uses much less water. Your motorhome is equipped with either a manual flush or macerator toilet depending on your model. Refer to the toilet operating owner's manual for further details and for on preparing the toilet for cold weather storage. When using the toilet, either the water demand pump should be turned on or the city water connection made and pressurized to assure a water supply to the toilet.

Gravity Flush

The gravity flush toilet is connected directly to a waste holding tank and has a water line routed to it for rinsing and flushing. There are separate levers on the side of the toilet for rinsing and flushing, and the instructions on the toilet should be followed for best results.

Tecma Macerator

The Tecma toilet is electronically flushed and has different modes for liquid or solid waste. Consult the Tecma owner's manual for instructions. This toilet has a tank sensor which prevents operation if your black water tank is full. You will need to dump your holding tanks to operate the toilet when this situation occurs.

OPERATING TIPS

1. Do not flush facial tissue or regular household toilet tissue down the motorhome toilet. It will not disintegrate properly and will cling to the sides and bottom of the holding tank, making it hard to clean. Use toilet tissue designed for RV toilets only.
2. Do not flush sanitary napkins or other nondissolving items down the RV toilet.
3. Do not use automotive antifreeze or caustic chemicals such as household bleach in the toilet or holding tank because they can damage plastic or rubber parts.

CLEANING THE MANUAL FLUSH TOILET

1. Clean the toilet regularly for sanitary reasons and to ensure efficient operation.
2. Clean the toilet using a mild bathroom cleanser. Do NOT use caustic or abrasive cleansers. Do not allow cleansers to remain in the toilet bowl for any length of time or damage to plastic surfaces and seals could result.
3. Dump and rinse the black water holding tank after cleaning and flushing the toilet.
4. Add a small amount of deodorizing agent every few days to eliminate toilet and holding tank odors.
5. If the operation of the manual flush valve is diminished or becomes stiff, lubricate the toilet plunger. Keep the toilet plunger lubricated by leaving a small amount of water in the toilet or turning off the water pump, draining all the water from the toilet bowl and lubricating the plunger O-ring inside the toilet. Operate the valve several times to make sure it is operating freely.

SHOWERS

HOT WATER

This standard water tap controls the flow of hot water to the shower head. Turn clockwise to turn off the water, and counterclockwise to turn on the water.

COLD WATER

This standard water tap controls the flow of cold water to the shower head. Turn clockwise to turn off the water, and counterclockwise to turn on the water.

INTERIOR SHOWER

Your motorhome is equipped with a full shower unit.



NOTICE

Lock the shower doors while in transit.

EXTERIOR SHOWER

Your motorhome is equipped with an exterior shower assembly which provides hot and cold running water for outdoor applications.

Specifications:

- Designed for use in a pressure regulated, portable water system with a maximum operating pressure of 40 psi.
- Maximum flow rate with the faucets fully opened - 2/5 GPM.
- DO NOT ALLOW TO FREEZE. (Do not overlook when winterizing)
- Do not connect directly to a high pressure residential water supply.



SECTION 8

LIQUID PROPANE GAS SYSTEM

Liquid Propane (LP) Gas	8-2
LP Gas Tank	8-4
LP Gas Leaks	8-6
LP Gas Regulator	8-7
Avoiding Asphyxiation	8-8
Mandatory Consumer Information	8-9

LIQUID PROPANE (LP) GAS

WHAT IS LP GAS?

LP (Liquid Petroleum) Gas is a colorless gas compressed into liquid form for easy transportation and storage. It is the energy source for your cook-top, furnace, hot water heater, LP generator, and an alternate energy source for your refrigerator. LP Gas is an excellent fuel source that is safe and economical when used properly.



These instructions are provided as a general guideline only. To ensure proper service and safety, always take your motorhome to a qualified service center.

LP GAS EMERGENCY SHUT OFF VALVE

Mercedes Models: Hand turn valve to open and close off LP from entering the system.

Ford Models: Uses Pull-Out / Push-In valve to open and close off LP from entering the system.

SAFE USE OF LP GAS

The LP Gas system is designed and built to adhere to federal government and industry regulatory requirements. Many safety devices and backup systems have been installed in your motorhome to improve safety and reliability. These devices and systems include the following: LP Gas tank overflow valves, LP Gas detectors, and carbon monoxide (CO) detectors. In addition, although LP Gas is naturally odorless, LP Gas contains an odor additive so it can be more easily detected.



Do not tamper with any part of the LP Gas system, piping or regulator. Service and maintenance must be performed by a qualified service center.

PRECAUTIONS FOR THE SAFE USE OF LP GAS

1. Familiarize yourself with the odor of LP Gas. If you suspect a leak, immediately turn off the LP Gas supply and have qualified service center determine the source of the leak.
2. Check the entire system for leaks every time the tank is filled. Take time to regularly inspect the system for leaks.
3. Turn off the LP Gas supply valve when the LP Gas system is not used.
4. Do NOT fill the LP Gas tank above 80% of its maximum capacity. LP Gas requires room to expand within the tank.
5. Make sure all appliance vents are open and free of obstruction when using the LP Gas system.
6. When drilling holes in walls or attaching objects, be careful not to damage gas lines or electrical wiring.

HOW LP GAS WORKS

There are two types of LP (liquid petroleum) Gas: propane and butane. Both are compressed into a liquid state for easier transportation and storage. Common names used for LP Gas are tank gas, bottle gas, or simply LP. In the tank, LP Gas is in liquid form and under very high pressure. As it is released, it changes to a vapor or gas and expands to a much greater volume. Exercise caution when temperatures fall below -40 °F (-40 °C). Propane will not convert from a liquid to a gas in extremely cold temperatures, and LP Gas appliances will not function properly.

SELECTING FUEL TYPES

Propane burns at a lower temperature and will convert from liquid to gas at temperatures as low as -40 °F (-40 °C). Butane is not recommended due to its high vaporization temperature 32 °F (0 °C). Using butane in cold temperatures may block the system and cause components to malfunction. LP gas dealers typically provide only the type of gas commonly used and suited for the climate in their area. If you travel from a warmer to a colder region, verify that you have the appropriate type of LP Gas for the climate.



The propane piping system is designed for use with propane only. Do not connect natural gas to this system. Securely cap inlet when not connected for use. After turning on propane, except after normal cylinder replacement, test propane piping and connections to appliances for leakage with soapy water or bubble solution. Do not use products that contain ammonia or chlorine to test for leaks, this may lead to a fire or explosion, which could result in death or serious injury.

LP GAS TANK

The LP Gas storage tank is mounted underneath the motorhome and is attached to the vehicle floor. It is accessible only from outside the vehicle. On all Mercedes models and the Ford transit the LP Gas storage tank is located on the driver side. For Ford E-450 models the LP Gas storage tank is located between the frame rails in front of the vehicle. Before turning on the LP Gas control valve make sure all controls for the various LP Gas appliances are in the “OFF” position to prevent any LP Gas from leaking into the motorhome.

NOTE: The LP Gas storage tank is also equipped with a manually operated shut-off valve.

On Mercedes and Ford Transit models there is a direct to tank fill valve. The direct fill valve is located behind the driver side running board.

On Ford E-450 models there is a remote fill port located behind the side entrance door on the passenger side of the motor home. There is a remote fill switch located below the remote fill port. Push the remote fill switch handle in for filling only, and pull out for normal operation. The remote fill switch requires constant power while pulled to the “out” (on) position. While your vehicle is stored it is recommended to push the remote fill switch “in” (to the off position) so the auxiliary batteries will not be drained. The switch is designed to meet safety requirements which state that the power must be off when filling the tank.



WARNING

These instructions are provided for your information only. The LP Gas Tank should only be filled by a qualified Propane Salesperson. Injury or death could occur if safety precautions are not followed. Turn off all LPG appliances and exit the vehicle when filling the tank.

REFILLING THE LP GAS TANK

1. Shut off the LP Gas control valve on the exterior before filling the tank or traveling. Always refill an empty LP Gas tank as soon as possible.
2. Connect the LP Gas supply to the fill connector.
3. Do NOT overfill your LP Gas tank. Stop filling when liquid appears at the overflow valve (often called a 10% valve) which limits the liquid level to 80% of container capacity, allowing 20% for expansion.
4. Check the LP Gas level after refilling by opening the overflow valve and bleeding gas in a well-ventilated area until the white liquid stops emerging from the overflow valve. Overfilling may cause damage to the regulator and cause malfunction of LP Gas appliances.

The tank is permanently mounted to the motorhome, therefore, the motorhome must be taken to a fueling station for refilling. When liquid LP Gas appears at the overflow valve, the tank is full. LP Gas stations are found in all parts of the country. Check the yellow pages in your telephone book or on-line if you have trouble finding a station.

Look under: “**Gas - Liquid Petroleum - Bottled and Bulk**” or “**Propane.**”



NOTICE

The LP Gas tank has an automatic 80% stop-fill device to prevent overfilling of the tank. To prevent against overfilling, have the tank filled only by an authorized filling station.



DANGER

Do NOT smoke when refueling. Keep flames, sparks and smoking material away from fuel or flammable fumes.



DANGER

- Never use an open flame to test for leaks.
- Never fill the LP Gas tank when either the engine or the generator is running.
- Keep all protective covers and caps in place.



DANGER

Never carry LP Gas or any other flammable liquid containers inside the living or driving areas of your motorhome. Gases may inadvertently be discharged into the confined space which could result in fire, asphyxiation or explosion.



WARNING

- Never overfill the LP Gas tank. Make sure your motorhome is level when filling the tank.
- Make sure all pilot lights are off before refueling any of the gas tanks on your motorhome.
- Do not smoke or have any open flame in the area where refueling is taking place.
- Use a soap and water solution to test for leaks in the LP Gas system.



WARNING

Remind the service attendant to use the 80% overflow valve when refueling. Space must be left in the tank for vaporization and expansion to occur.

AFTER REFILLING THE LP GAS TANK

1. Periodically check all containers and line connections to be sure they are tight. Use soapy water when testing for leaks - do NOT use an open flame.
2. If you notice a gas, diesel or LP Gas fumes at any time, immediately determine and correct the source of the problem.
3. Before opening the LP Gas control valve in the exterior utility center, check that controls for all gas appliances are in the "OFF" position. An accumulation of LP Gas inside the motorhome could create a fire or explosion hazard.
4. Remember, LP Gas is potentially lethal if inhaled.

AIR IN THE LP GAS TANK

If your LP Gas appliances burn poorly or do not stay lit even though there is a sufficient fuel supply, there may be air trapped in the LP Gas tank. The air should eventually escape along with the LP Gas, but it may be necessary to have your LP Gas tank purged of air by your LP Gas dealer.

TRAVELING WITH LP GAS

In some jurisdictions it is illegal to transport LP Gas on certain roads or through tunnels. Check state or provincial regulations to make sure your trip will not be halted or impeded unexpectedly as a result of transporting LP Gas.

LP GAS LEAKS

Read, understand and follow the safety label affixed near the range area in your motorhome's galley. Do NOT remove this label. If you ever smell LP Gas inside the vehicle or if the detector alarm sounds, carefully follow the instructions on the label. Road vibration can loosen propane fittings. Check the propane system for leaks at least every 5000 miles (8000 km) and whenever the tank is refilled. Have the entire propane system inspected annually by qualified service personnel regardless of the number of miles driven.

1. Read, understand and follow safety labels, signs and directions in the motorhome.
2. Use soapy water to check for leaks and watch for bubbles. Never use an open flame.
3. Correct or repair leaks before using appliances or operating the vehicle.



DANGER

If you smell propane, follow these steps:

1. Extinguish all open flames, pilot lights and smoking materials.
2. Do NOT touch any electrical switches.
3. Shut off the propane supply at the tank valves or propane supply connections.
4. Open doors, windows and vents.
5. Leave the area until the odor clears.
6. Have the propane system checked and repaired by a qualified service technician before using the LP Gas system. Failure to comply could result in asphyxiation, fire or explosion causing serious injury or death.

LP GAS REGULATOR

The LP gas system uses a two-stage Regulator to control the pressure to the LP gas appliances to assure the proper functioning and safe operation of the appliances. The pressure regulator has a vent hole on the underside. The regulator is located under the floor of the motor home near the LP gas storage tank and is enclosed in a protective shield to prevent damage to the regulator or clogging of the vent. Make sure this vent hole is open and not obstructed in any way. If the motor home is driven through heavy snow or mud, the vent opening should be checked to make sure that it is not clogged by snow, mud or ice. An opening in the bottom of the shelf allows access to the vent. The LP gas tank regulator has a plastic cover to protect it from the weather. Only qualified service personnel are permitted to remove this cover.

An LP Gas regulator may freeze in extremely cold temperatures. This may result from a small amount of moisture in the fuel, even though LP Gas dealers take precautions to prevent this from happening. Under some conditions, moisture may be present in the LP gas in your tank and this can cause the regulator to freeze up, stopping flow to the appliances. Keep the LP gas control valve closed when not in use, even when the LP Gas tank is empty. This helps to prevent condensation from forming and helps to prevent freezing. If necessary, hold an incandescent light bulb near the regulator to thaw it. This condition occurs more frequently in cold weather or at higher altitudes and usually can be cured or prevented by having methanol injected into the LP gas tank.

If moisture in the LP Gas tank is a recurring problem, ask your LP Gas dealer to inject a small amount of dry methyl alcohol into the tank to absorb the moisture. Only experienced, qualified personnel should do this. Some LP gas stations especially at higher altitudes, will already have methanol in the LP gas they dispense. It is suggested that if you plan to go to a colder climate or a higher altitude, that you wait until you reach those areas before completely filling your tank. The small cost difference is well worth it to reduce the risk of freeze up.

LP Gas vaporizes quickly and easily in warmer temperatures. In colder conditions, this vaporization process significantly slows down. When large amounts of fuel are required, when using the furnace for example, the fuel may not vaporize rapidly enough to keep all the appliances operating at a high level. In this case, you may have to reduce the consumption of fuel by lowering the temperature setting on the furnace, reducing the consumption of hot water, turning down the temperature setting on your refrigerator, or switching from LP gas to electric power if possible.

The LP gas regulator pressure is preset. Do NOT attempt to adjust it. Adjustments must only be performed by an authorized service center. Do NOT expose the regulator to the elements. If the LP gas regulator fails, the LP gas tank may be overfilled or impurities may mix with the propane. Regulator failure could cause LP gas components to malfunction.



CAUTION

Do not use an open flame or a heat lamp to thaw the regulator.

AVOIDING ASPHYXIATION

1. Do not use portable fuel-burning equipment such as wood or charcoal grills, heaters or stoves inside the motorhome. The use of this equipment can produce deadly carbon monoxide gas or cause fires.



Do not bring or store LP Gas containers, gasoline or other flammable liquids inside the motorhome because a fire or explosion may result.

Do not use materials that contain ammonia or chlorine to check for LP Gas leaks.

2. Ensure there is proper ventilation before using the gas range to prevent asphyxiation. Do NOT use the range to heat the motorhome. Long term use of these appliances for space heating increases the chance of asphyxiation. Open the overhead vent and open a window before using the range.
3. Avoid breathing the exhaust fumes from gas or diesel engines and LP Gas burners. Poisonous exhaust fumes are produced from operating the motorhome or generator engine, stove, oven, refrigerator, furnace and hot water heater. Position the motorhome so the wind blows exhaust fumes away from the motorhome. Ensure proper ventilation and adequate air exchange when using LP Gas appliances to prevent a buildup of deadly carbon monoxide gas. Be sure all alarms are in proper working condition.
4. Do not run the motorhome or generator engine in a confined area such as a garage, except to remove the motorhome from the confined area.
5. Use the vent or air conditioning fan to force fresh air into the motorhome if the vehicle is not moving but the engine is running for more than just a few minutes.
6. Maintain engine and generator exhaust system components to prevent fumes from entering the motorhome. Check exhaust systems when changing oil, when exhaust system sounds change or when the under-body of the motorhome makes contact with an object or becomes damaged.
7. Close rear windows when driving to prevent drawing exhaust fumes into the motorhome.

NOTE: When the motorhome is new, some of the appliances will burn off paint or residue which has accumulated during production. You also may notice some odors from cleaners which will dissipate with use and ventilation.

MANDATORY CONSUMER INFORMATION

The following information is being supplied to conform with the mandates of:

ANSI A119.2 / NFPA 501C-1987

and to ensure the greatest possible degree of safety for our customers. Please study this information carefully and keep it in your vehicle at all times. Should this information be misplaced, additional copies are available from our corporate office for a nominal charge.



Before operation:

1. Open overhead vent or turn on exhaust fan.
2. Open window.

If you smell gas, immediately follow these steps:

1. Extinguish open flames, pilot lights and all smoking material.
2. Do not touch any electrical switches.
3. Shut off LP Gas tank valve.
4. Open doors, windows, and roof vents after making sure the roof vent fans are "OFF".
5. Leave the motorhome and it's immediate vicinity until odor is gone.
6. Have a qualified service technician check the system for leaks and make any necessary corrections and repairs.

NOTE: Do not remove labels.

LP gas containers shall not be placed or stored inside the vehicle.

LP gas containers are equipped with safety devices which relieve excessive pressure by discharging gas to the atmosphere.

It is not safe to use cooking appliances for comfort heating.

Cooking appliances need fresh air for safe operation.

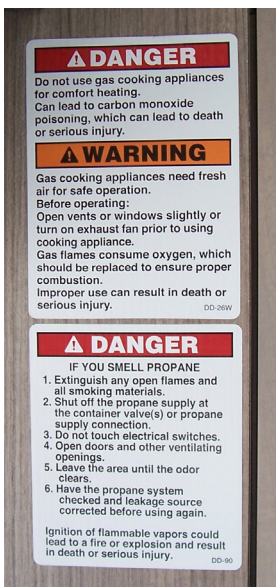

A warning label has been located in the cooking area to remind you to provide an adequate supply of fresh air for combustion.

Unlike homes, the amount of oxygen supply is limited to the size of the recreational vehicle, and proper ventilation when using the cooking appliance(s) will avoid danger.

Cooking appliances should not be used for comfort heating as danger of asphyxiation is greater when appliance is used for long periods of time.

**DANGER**

All pilot lights, appliances and their igniters (see operating instructions) shall be turned off before refueling of motor fuel tanks and/or propane containers. Can cause ignition of flammable vapors, which can lead to a fire or explosion and result in death or serious injury.

Never use an open flame to test for leaks.

Never fill LP gas tank when either the engine or generator is running.

Keep all protective covers and caps in place.

Never carry LP gas or any other flammable liquid containers inside the living or driving areas of your motorhome, Gases may inadvertently be discharged into the confined space which could result in fire, asphyxiation, or explosion.

**WARNING**

Do not fill propane container(s) to more than 80 percent of capacity. A properly filled container contains approximately 80 percent of its volume as liquid propane.

Overfilling the propane container(s) can result in uncontrolled propane flow which could lead to a fire or explosion and result in death or serious injury.

Remind the service attendant to use the 80% overflow valve when refueling. Space must be left in the tank for vaporization and expansion to occur.

Never overfill the LP gas tank. Make sure your motorhome is level when filling the tank.

Make sure all pilot lights are off before refueling any of the fuel tanks on your motorhome.

Do not smoke or have any open flame in the area where refueling is taking place.

Use a soap and water solution to test for leaks in the LP gas system.

**NOTICE**

In some jurisdictions it is illegal to transport LP gas on certain roads or through tunnels. Check state or local regulations to make sure your trip will not be halted or impeded unexpectedly as a result of transporting LP Gas.

SECTION 9

MAINTENANCE / MISCELLANEOUS

Exterior Care	9-2
Interior Care	9-6
Storage	9-8
Water System Winterization	9-9
Mor/Ryde Suspension	9-11
Maintenance and Servicing	9-12

EXTERIOR CARE

ROOF

The roof is strong enough to support the weight of an average adult if it becomes necessary to repair the roof or any of the roof mounted components. It is advised that a harness system be used from up above if possible for optimal safety. Avoid carrying large heavy objects onto the roof. The additional strain of the weight, along with the movement of the motorhome, could cause damage to the roof. Check the roof regularly for possible leaks, especially the sealant around the vents, air conditioners, and etc. Immediately repair any suspected leaks. Any leakage could result in damage to the interior of the motorhome.

UNDERBODY

Mud and dirt mixed with corrosive materials used to control dust or ice on the roads can accumulate underneath your motorhome and cause premature deterioration and rusting. In addition, any build up will add unnecessary weight to the motorhome. Rinse and flush the undercarriage and the entire under-body every time you wash the motorhome.

EXTERIOR LIGHTING

Before each trip, inspect all clearance lights, identification lights, marker lights, stop lights, turn signal lights and backup lights. Immediately replace burned out bulbs. Use soap and water to keep all light lenses clean.

SOLAR PANELS

Solar panels should be cleaned monthly using water and a soft sponge or cloth. If required, a mild nonabrasive cleanser can be used for more stubborn residue. Ensure solar panels are rinsed thoroughly following cleaning. For best performance, solar panels should be cleaned more frequently during drier months as they may become covered in dust more quickly. Use of a pressure washer to clean the solar panels is not recommended.



NOTICE

Solar panels contain acrylic (Plexiglas®) components. Refer to the acrylic manufacturer's cleaning instructions. Do NOT clean using Windex® style glass cleaners.

EXTERIOR MAINTENANCE

Damaging salts, calcium chloride, road tar, tree sap, insects and other foreign material can accumulate on the body of your motorhome. To reduce the harmful effects of these agents, wash the motorhome frequently and thoroughly using mild soap and warm water. Do not wash the exterior in direct sunlight and never use hot water. Avoid using pressure washers because they can loosen decals and sealants. Regularly wax your RV to reduce the negative effects of UV exposure on the exterior fiberglass parts.

Carefully inspect all caulking around windows, doors, vents and all other joints. Re-caulk if necessary using the correct caulking material available from a qualified service center. If water fails to bead on the surface of the motorhome, it is time to polish and wax it. This will not only improve the appearance of your motorhome, but will also protect the painted surfaces from oxidation and corrosion making it easier to wash.

TAKING CARE OF EXTERIOR FINISH

PREMIUM PAINTING CARE: Your Coach House has been painted with base coat and clear coat premium products. We recommend that you wash the finish with mild soap and water.

WAX FINISH: The finish may be waxed with an automotive wax that has been labeled as “safe for clear coat”.

Following these procedures can provide a long-lasting, high-gloss finish to your RV. These same procedures can also be applied to your everyday automobile, producing the same long-lasting results. The clear coat used on all painted Coach House RV's is similar to the technology used by automotive manufacturers. The end result is a Master-piece finish which is the highest quality in the industry. The same care needs to be performed and maintained on the RV exterior surface as on an automobile finish.

Make sure the RV's surface temperature is under 90 degrees F, and is not in direct sunlight. Rinse the entire coach to remove all loose dirt and grime. Never hold a pressure washer close to the surface. Use a fan type spray nozzle, making sure that the water coming out of the gun has a fan and not a single straight stream. Most automotive stores offer mild car wash shampoos that are safe for clear coat finishes.

We recommend using baby shampoo as it will not leave a film on the painted finish. Adding 1/2 of a cup of food grade vinegar to the water will boost the cleaning ability of any cleaner and also soften the water. This also helps to minimize water spots. Do not use dish soap, detergents with degreasing agents, or industrial cleaners as they can cause damage to the finish. Use a 100% cotton or Lambs-wool pad or wash mitt for washing the painted surface of the RV. Use a different mitt for washing the wheels and undercarriage. Change water in the wash bucket often or place a “dirt guard” in the bottom of the bucket to keep the cleaning pad or wash mitt free of dirt and debris.

ABSOLUTELY NO BRUSHES SHOULD BE USED ON THE PAINTED SURFACE. USE OF THESE ON YOUR RV'S PAINTED SURFACE WILL CAUSE DAMAGE TO THE FINISH, AS IT WOULD AN AUTOMOBILE FINISH. COACH HOUSE DOES NOT SUPPORT USING ANY STYLE, TYPE, MATERIAL OF BRUSH EVEN THOUGH IT MAY BE MARKETED AS “RV SAFE” OR “APPROVED.”

Damage caused by inappropriate or unapplied maintenance is not covered under warranty as expressed in the Coach House Expressed Limited Written Warranty.

DRYING YOUR RV

Drying the RV is just as important as washing it. Today's tap water and well water contains many chemicals that could leave water stains on the finish. After washing, dry the RV with a squeegee or a clean 100% leather chamois. You can also use fresh Microfiber towels for drying. Please use caution as these towels are made partially with polyester (which is plastic) which can break down over time from extended use and washing, eventually causing damage to the clear coat finish.

WAXES AND POLISHES

Over 90% of all passenger vehicles are clear-coated. The finish on your RV is a state of the art Acrylic Urethane Basecoat / Clearcoat. This means that what you wax and polish is a clear urethane coating designed to protect the basecoat, the pigmented coating that provides color. As its main function of protecting the basecoat, clearcoats need to be maintained, especially in harsh environments. Clearcoats do not fade themselves, but appear to fade or lose gloss as the surface becomes contaminated by the environment. If this contamination is not removed frequently, results will be a dull or low-gloss finish. Occasional washing alone will not adequately remove some forms of contamination and will require polishing.

Polishes and waxes primarily serve the following purposes:

- 1) To remove minor surface imperfections caused by water spots and acid rain.
- 2) To remove minor scratches by filling them and leveling the surface.
- 3) To seal the pores of the finish creating an easier-to-clean surface.
- 4) To beautify the paint finish appearance with more depth and high gloss.
- 5) To protect the paint finish from the elements.

Do not use products that contain harsh abrasives such as rubbing compounds. These products should be used by an experienced technician with proper training and equipment. Most polishes and waxes are designed to clean and polish in one application, whether by hand or machine.

A machine applied polish will last longer than one applied by hand because the high RPM of the buffing wheel creates heat, resulting in a deeper film with higher gloss. However, a hand-applied polish or wax will offer outstanding performance and protect the RV's finish. Use only a sponge buffing pad to prevent "burn through".

When applying polish or wax, do so in a shaded area making sure the RV surface is at the specified temperature according to the polish manufacturer's recommendations. Due to the variations of polishes and waxes, incorporate the following suggestions into the polishing technique:

- 1) Condition the polishing pad by rubbing a slight amount of polish on it.
- 2) Use only the amount of polish specified in the label directions.
- 3) Work a small area at a time.
- 4) Rinse off and remove dried polish from crevices, trim, and moldings.

For optimum results, refrain from waxing or polishing for 60 days from date of manufacture.



These instructions are provided as a general guideline only and may not be complete. To ensure proper service and safety, always take your motorhome to a qualified service center.

EXTERIOR DECAL CARE

Follow these steps for the care and maintenance of your motorhome's stripes and decals:

- Wash with mild soap and warm water and rinse thoroughly.
- Never wash using a high-pressure washer at close range. The force of the water can lift the edges of decals.
- Do not use solvents. They can smear the colors and damage the adhesive.
- Never use lacquer thinner or paint on decals.
- Avoid splashing gasoline or diesel fuel on stripes and decals and rinse immediately if splashing occurs.

ALCOA ALUMINUM RIMS (OPTIONAL)

THE BEST WAY TO CLEAN ALUMINUM WHEELS

Aluminum wheels can shine like chrome when they are cleaned and polished to perfection. Since aluminum is one of the softer metals, it responds quite well to polishing. If you want to keep your aluminum wheels in good condition, you should clean and polish them regularly. Here is some information about the best way to clean aluminum wheels.

Before you wash your vehicle, you should clean the aluminum wheels. Cleaning the aluminum wheels prior to cleaning the vehicle will prevent dirty water and dust from dirtying your clean car. Here are the steps you should follow to clean aluminum wheels.

Use water to rinse the aluminum wheels. This will remove any loose dust and dirt on the wheels. You will want to use a nozzle to create a powerful stream of water. Rinse all the crevices of a wheel, including the spokes and the brake calipers.

You should use an aluminum wheel cleaner to spray the wheels. The cleaner should be non-acidic. A non-acidic cleaner will clean the wheel effectively without spotting. Then, use a wheel brush with soft bristles to clean the wheel. Don't use a brush with hard bristles to clean the wheel. Hard bristles will likely scratch the aluminum and you will need to work hard to get rid of the scratches by polishing. The soft bristles of a brush will loosen the dirt and grime without leaving scratches on the wheel finish.

Be sure to dry the wheels. Water spots on wheels are unattractive. Use a microfiber towel to preserve the wheel finish and to remove loose brake dust. Ideally, you should use a black towel so that you can clean the aluminum wheels without ruining the towel. Use a different towel for drying your vehicle because you don't want brake dust on your car's paint.

INTERIOR CARE

Dirt and dust accumulation can not only detract from the motorhome's appearance, but can also shorten the life of carpets and fabrics. Clean and vacuum weekly to keep your motorhome in pristine condition.

UPHOLSTERY

Use care when cleaning the motorhome's upholstery and choose an appropriate cleaner or spot remover to avoid damaging the materials. Regular vacuuming and wiping with clear water will remove most stains. Any major cleaning problems should be referred to a professional cleaning service.



NOTICE

Direct sunlight will fade upholstery and fabrics. To minimize fading, close drapes, blinds and shades whenever possible.

SPOTS AND STAINS

Most spots and stains can be removed using clear warm water. To prevent a stain from spreading, start from the outside of the stain and clean toward the center. Stains such as lipstick, grease, ink or mustard are very hard to remove and might require the help of a professional cleaning service.

VINYL FABRICS

Clean vinyl surfaces using a soft, damp cloth and mild detergent. Never use solvents of any kind on vinyl surfaces.

NOTE: The vinyl manufacturer recommends the following: "To clean most common household stains use warm soapy water and a clear water rinse. For more stubborn stains, Fantastik™ or Mr. Clean™ diluted 3:1 with water are recommended.

DRAPERIES, CURTAINS AND BEDSPREADS

Draperies, curtains and bedspreads are made from a variety of fabrics and materials. Many of these materials could shrink up to 5 percent during the cleaning process. Always use a professional cleaning service for you motorhome's textiles.



NOTICE

Using water-based or detergent-based solvent cleaners on fabrics may cause excessive shrinkage and permanent stains.

CABINETS, TABLES AND COUNTERTOPS

The wood's beauty comes from the natural variations in grain and density. Some minor variations in color and shading are normal.

WALLS

Clean walls using warm water and mild soap. For extensive accumulations of dirt and grime, add a small quantity of rubbing alcohol to the water. Do NOT use solvents or abrasives.

SINKS

The sinks can be cleaned with warm water and soap. Wipe dry to avoid streaks. For stubborn stains, a mild abrasive may be necessary. Always work in the direction of the polish lines.

BATHROOM - GENERAL

Use warm water and mild soap to clean the walls and surfaces in your bathroom. Clean mirrors using a good-quality glass cleaner. Do NOT use harsh cleansers, detergents or abrasives. Refer to the toilet manual for cleaning and care instructions.

DOORS AND WINDOWS

Periodically lubricate the door locks and hinges with powdered graphite for smooth operation and protection from freezing. Clean windows using a good quality glass cleaner. If cleaning ice from windows, use a plastic scraper and avoid damaging the seals and sealant along the edge of the windows.

REFRIGERATOR

Clean the refrigerator interior regularly. Remove the shelves and wash inside the refrigerator using warm water and mild soap. Dry thoroughly, especially around door frame and door gasket. Use only warm water to clean the cooling evaporator, ice trays and shelves. Never use strong chemicals or abrasive cleaning materials on any part of the refrigerator cabinet. Refer to the refrigerator manual for additional information.

STOVE TOP - GENERAL

Clean the stove top as soon as it cools using warm water and a mild detergent solution. Clean the stove top regularly to help keep the appliance looking and operating like new.

STOVE TOP - BURNERS

Clean the stove top burners (caps and grates) after they have cooled using warm water and a mild detergent solution. Clean plugged burner ports with a toothpick. Do NOT clean burner ports using metal objects of any kind because it could enlarge the port. If washing a cap or grate in the sink, dry it immediately by shaking off all excess water, reinstalling it onto the stove top and lighting the burner until all water evaporates.

MICROWAVE / CONVECTION OVEN

Keep the door and inside of your microwave/convection oven clean. Do not allow grease, spatter or solid matter to build up. An accumulation of solid matter can absorb microwave energy and increase cooking time. Clean the microwave/convection oven as follows:

- Wipe walls with a damp cloth and mild detergent to remove spatters and spills. Do not use harsh detergents or abrasives.
- Clean the outside surface of the oven with soap and water. Rinse and dry with a soft cloth.
- Do NOT allow water to enter the oven's ventilation openings to avoid damaging the oven's internal components.
- If the control panel becomes wet, clean it with a soft dry cloth. Do not use harsh detergents or abrasives on the control panel. When cleaning the control panel, leave the oven door open to prevent the oven from accidentally turning on. After cleaning, touch the cancel pad to clear the display window. Remove the glass tray for cleaning. Wash the tray in warm soapy water or in a dishwasher.
- Refer to the microwave/convection oven manual for further details.

STORAGE

Inspect all systems, components and appliances prior to storing your motorhome: Fill the motorhome fuel tank to reduce excessive moisture buildup. Check coolant level and add antifreeze if necessary. Use an appropriate coolant/water ratio that will protect to the lowest temperature expected during the storage period. Change the engine oil to the recommended viscosity to aid with cold weather starting. Park the motorhome as level as possible.

Ensure the battery has a full charge, then disconnect both coach batteries using the battery disconnect switch in the coach. Disconnect the Chassis batteries by disconnecting the negative terminal on the batteries. Charge the batteries monthly with a trickle charger or smart charger. Wash the motorhome. If exposed to road salts, thoroughly wash and flush the exterior and undercarriage.

Remove all perishable items and anything that can freeze (canned goods, medicine, etc). Leave the refrigerator door ajar. Ensure all controls are turned off. Ventilate the living area by opening drawers, cabinets, closets, etc. Drain the gray and black water holding tanks, toilet and living area water system. Deodorize and allow to dry. Turn off the water heater and drain the fresh water tank and water heater. Turn off the LP Gas tank valve.

COLD TEMPERATURE STORAGE SPRING STARTUP

After storing the motorhome for an extended period of time, run the water pump to pressurize the water system and check for leaks. Visually inspect the water system for 15 minutes to ensure there are no leaks. Clean all your appliances and have the LP Gas line purged by a qualified service center. Ensure everything in the motorhome is working correctly. Refer to the chassis manual for any chassis maintenance recommendations.

COLD TEMPERATURE OPERATION

The plumbing system in this motorhome is designed for cold weather providing the interior temperatures do not fall below freezing. Temperatures at or below freezing will cause damage to the plumbing system.

CHASSIS: Check engine coolant level and add antifreeze, if required, to protect against lowest expected temperature. Change engine oil to the recommended viscosity to aid cold weather starting. Refer to the chassis manual for further recommendations.

LP GAS: Use propane for winter traveling because it will vaporize in extremely cold temperatures -40 °F (-40 °C). Butane is not recommended due to its high vaporization temperature 32 °F (0 °C). Using butane in cold temperatures may block the system and cause components to malfunction.

WASTE SYSTEM: Prevent winter freeze-up by adding regular non-toxic RV antifreeze into the toilet and kitchen drains to protect the holding tanks from freezing. Be sure to add a sufficient amount of non-toxic RV antifreeze to protect the total volume of the holding tanks.



WARNING

Do NOT use alcohol-based antifreeze or other petroleum products.

WATER SYSTEM WINTERIZATION

DRAIN THE WATER SYSTEM

If the water heater contents are still hot, serious burns and scalding may occur. Failure to drain the water heater reservoir may cause damage to the water heater. Ensure no air pressure or winterization fluid enters the water heater as part of this process.

1. Switch off the water pump and disconnect the water hose at city water outside.
2. Switch off the water heater inside the motorhome.
3. Switch off LP Gas in the outside utility compartment.
4. Drain the fresh water tank. Leave the water tank valve open for winter storage.
5. Relieve the water pressure by opening the hot and cold taps on any faucet.
6. If heater is still hot, be sure to allow the water to cool before proceeding.
7. Drain the water heater, avoid the risk of being scalded.
8. Close water heater valves after complete drain of the system.
9. At this point, you can continue the winterizing process by either adding plumbing anti-freeze to the system, or blowing out the airlines.

ANTIFREEZE METHOD

If you wish to absolutely make sure your water lines are protected you can perform the following. The reason for putting antifreeze through your lines is in case any water collects at low levels of your water lines and freezes. This could be enough to rupture a line. Putting RV antifreeze through your lines will eliminate this from being an issue.

NOTE: Be sure to use RV Antifreeze. NOT automotive radiator antifreeze.

1. Your water heater is equipped with a bypass kit. Drain the water from the water heater and set the valves for the “bypass” position.
2. Pour 2-3 Gallons of RV antifreeze in the Fresh Water Fill inlet which is located on the passenger side of your motorhome.
3. Turn on the R.V. water pump which will pull the antifreeze out of the fresh water tank and into the system. Open each fixture, allowing it to flow until you see pure antifreeze. Monitor the level in the antifreeze bottle and make sure it doesn't run dry. Remember to flush the toilet and operate the toilet sprayer if installed. Don't forget the shower head and the outside shower if you have one. Once you have done each and every fixture, you should have protection against freezing pipes in your water system.
4. Once you have the RV parked in it's final storage spot for the winter, pour some RV antifreeze down each drain to protect the trap. Open the toilet flush valve and allow about one quart (4 cups) of antifreeze to flow into the black water tank. Close the toilet flush valve and pour a little antifreeze into the toilet bowl. Pour about one quart (4 cups) down the shower drain to flow into the gray water tank.

NOTE: Your water heater has specific winterizing instructions. Refer to the manual for complete instructions.

BLOW-OUT PLUG METHOD

1. Drain the black and gray waste holding tanks. Then thoroughly rinse both the black and gray waste holding tanks at a sanitary dump station.
2. Drain the fresh water tank. The fresh water tank drain is accessible from inside.
3. Drain all water lines. Drain valves are located behind a hinged panel on the rear of the driver's side of motor home. Be sure to drain shower, toilet and all faucets. If a water purifier or filter is in line, remove the cartridge. Close all faucets.
4. Install an R.V. "Blow-Out Plug" on your city water inlet.
These plugs are inexpensive and are available at R.V. Parts stores or Home Improvement stores (Lowe's, Home Depot)
5. Set your air compressor to 30 psi, connect air line to the blow-out plug, and start blowing air into the water inlet.



NOTE: DO NOT FLUSH NON-MACERATOR TOILETS AT THIS TIME.



NOTICE

Do NOT depress the toilet flush pedal if there is air pressure in the system or damage to the toilet flush valve could result.

6. While your compressor is blowing air into your water lines, walk around your RV and open up all hot and cold water faucets (including interior and exterior shower faucets, bathroom and galley sinks), one at a time, to blow the water out from the lines.
 - Don't forget the shower head and the outside shower.
 - Don't forget to open up both the hot water and the cold water drain valves.
 - When the water has been blown out then close the valve and move on to the next water opening. Remember to flush only the MACERATOR toilet.
7. (A) Flush ONLY the MACERATOR toilet. Once every fixture is opened most of the water will be out of the fresh water system. Disconnect the compressed air line and remove the blow-out plug. Release air pressure by opening all faucets.
7. (B) For NON-MACERATOR (regular toilets): After releasing all air pressure from the lines, depress the toilet flush lever while an assistant applies compressed air into the blow-out plug. Disconnect the compressed air line and remove the blow-out plug. Release air pressure by opening all faucets.
8. Add approximately 1 cup of non-toxic plumbing antifreeze to the kitchen sink, bathroom sink, shower drain and toilet bowl.
9. At this point, your RV has been winterized.

DE-WINTERIZING THE WATER SYSTEM

NOTE: Flush entire water system before filling the hot water tank.

1. Refill the water tank with fresh city water.
2. Turn the bypass valve to the "NORMAL FLOW" position.
3. Turn the hot water heater valves to the "NORMAL FLOW" position.
4. Turn on the water pump switch
5. Open the water faucet furthest away from the water tank. Run the water until clear water appears then shut off the faucet. Repeat this procedure for all remaining faucets including the shower and exterior faucets.
6. Open the hot water line until clear water appears.

MOR/RYPDE SUSPENSION

All Ford Chassis, except for the 220 models, are equipped with MOR/ryde suspension enhancements to smooth out the ride and dampen road irregularities. This system has been adjusted for the E-450 chassis and your Coach House motorhome. No adjustments or maintenance should be required for the life of your vehicle.



MAINTENANCE AND SERVICING

ENTRY DOOR STEP

Periodically clean and lubricate the electric entry door step mechanism. Refer to the electric step manual for details.

LEVELING SYSTEM (OPTION)

Periodically check the transmission fluid in the pump reservoir and refill as necessary. Refer to the leveling system manual for details.

12 TON BOTTLE JACK - EMERGENCY USE

Mercedes models come from the factory with bottle jack included. Ford models do not. Either way Coach House provides all of its Motor Homes with a 12 Ton Bottle Jack for emergency use. Bottle Jack color and make may vary but design and use are the same.

PRODUCT SPECIFICATIONS

MODEL #:	7384
DESCRIPTION:	BOTTLE JACK
CAPACITY:	12 TON
JACK SIZE:	5 1/4" (L) X 5 1/8" (W)
MIN. HEIGHT:	9 3/8"
MAX. HEIGHT:	18 1/2"
SCREW EXT.:	3 1/8"
HANDLE LENGTH:	18 1/8"
OPERATING FORCE:	102.0 LBS
SADDLE DIM.:	1 3/4"
NET WEIGHT:	17.4 LBS
VOLUME OF HD. OIL:	360 C.C.
COLOR BOX DIM.:	5 5/8" (L) X 5 1/2" (W) X 10 1/4" (H)
GROSS WEIGHT:	72.6 LBS / 4 PCs
CARTON BOX DIM.:	11 7/8" (L) X 11 5/8" (W) X 11 3/8" (H)
CUFT.:	0.91 CUFT (2120 PCs/ 20' CTN)

FEATURE

- MEETS ASME/ANSI - PALD SAFETY STANDARDS
- LIFTING RANGE: 9 3/8" TO 18 1/2"
- PATENTED BUILT-IN BY-PASS DEVICE MECHANISM
- TWO PCS. HANDLE
- HEAT TREATED EXTENSION SCREW



ONE YEAR LIMITED WARRANTY

For a period of one (1) year from date of purchase, **ATD Tools Inc.** will repair or replace, at its option, without charge, any of its products which fails due to a defect in material or workmanship under normal usage. This limited warranty is a consumer's exclusive remedy.

Performance of any obligation under this warranty may be obtained by returning the warranted product, freight prepaid, to **ATD Tools Inc.** Warranty Service Department, 160 Enterprise Drive, Wentzville, MO 63385.

Except where such limitations and exclusions are specifically prohibited by applicable law, (1) THE CONSUMER'S SOLE AND EXCLUSIVE REMEDY SHALL BE THE REPAIR OR REPLACEMENT OF DEFECTIVE PRODUCTS AS DESCRIBED ABOVE. (2) **ATD Tools Inc.** SHALL NOT BE LIABLE FOR ANY CONSEQUENTIAL OR INCIDENTAL DAMAGE OR LOSS WHATSOEVER. (3) ANY IMPLIED WARRANTIES, INCLUDING WITHOUT LIMITATION THE IMPLIED WARRANTIES OF MERCHANTABILITY AND FITNESS FOR A PARTICULAR PURPOSE, SHALL BE LIMITED TO ONE YEAR, OTHERWISE THE REPAIR, REPLACEMENT OR REFUND AS PROVIDED UNDER THIS EXPRESS LIMITED WARRANTY IS THE EXCLUSIVE REMEDY OF THE CONSUMER, AND IS PROVIDED IN LIEU OF ALL OTHER WARRANTIES, EXPRESS OR IMPLIED. (4) ANY MODIFICATION, ALTERATION, ABUSE, UNAUTHORIZED SERVICE OR ORNAMENTAL DESIGN VOIDS THIS WARRANTY AND IS NOT COVERED BY THIS WARRANTY.

Some states do not allow limitations on how long an implied warranty lasts, so the above limitation may not apply to you. Some states do not allow the exclusion or limitation of incidental or consequential damages, so the above limitation or exclusion may not apply to you. This warranty gives you specific legal rights, and you may also have other rights which vary from state to state.



SAFETY INSTRUCTIONS

BEFORE USE

1. Verify that the product and the application are compatible.
2. Before using this product, read the owner's manual completely and familiarize yourself thoroughly with the product, its components and recognize the hazards associated with its improper use.
3. Open the release valve (counter-clockwise no more than 1/2 full turn).
4. With ram fully retracted, locate and remove the oil filler plug. Insert the handle into the handle sleeve, then pump 6 to 8 strokes. This will help release any pressurized air which may be trapped within the reservoir. Ensure the oil level is just below the oil filler plug hole. Reinstall the oil filler plug.
5. Check to ensure that jack rolls freely (if so equipped) and that the pump operates smoothly before putting into service. Replace worn or damaged parts and assemblies with AtD Tools Authorized Replacement Parts only. (See Replacement Parts Section)
6. Inspect before each use. Do not use if bent, broken or cracked components are noted.

 WARNING
<ul style="list-style-type: none"> • Study, understand, and follow all instructions provided with and on this device before use. • Do not exceed rated capacity. • Use only on hard, level surfaces capable of sustaining rated capacity loads. • Lifting device only. • Immediately after lifting, support the vehicle with appropriately rated stands • Never work on, under or around a load supported by this device. • Failure to heed these markings may result in personal injury and/or property damage.



OPERATION

Lifting

1. Assemble handle, ensure that spring clips align with slots.
2. Secure the load to prevent inadvertent shifting and movement.
3. Place vehicle in part gear.
4. Position the jack near desired lift point.
5. Close the release valve by turning it clockwise until it is firmly closed.

Note: Use the handle provided with this product or an authorized replacement handle to ensure proper release valve operation. When using to lift vehicle, lift only on the manufacturer's recommended lift points and in accordance with the published guidelines in your vehicle owners manual. Always use jack stands to support the load immediately after lifting.

5. Insert and secure handle into handle sleeve. Pump handle until saddle contacts load.
6. Raise load to desired height, then immediately transfer the load to appropriately rated support devices such as jack stands.

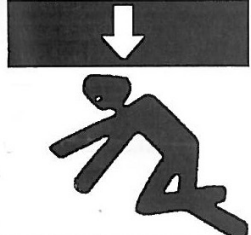
 WARNING	
	<p>To avoid crushing and related injuries: NEVER work on, under or around a load supported only by jack. ALWAYS use adequately rated jack stands.</p>

Lowering

1. Raise load enough to carefully remove jack stands.
2. Insert handle onto release valve and slowly turn handle counterclockwise, but no more than 1/2 turn.
3. If load fails to lower:
 - a. Carefully transfer the load to another lifting device and jack stands.
 - b. Carefully remove affected jack, and then the jack stands. Lower the load, again by slowly turning the release valve no more than 1/2 turn.

<p>! SAFETY MESSAGE !</p> <p>Be sure all tools and personnel are clear before lowering load. No alterations shall be made to this device. Only attachments and/or adapters supplied by the manufacturer shall be used.</p>

4. After removing jack from under the load, push ram and handle sleeve down to reduce exposure to rust and contamination.

SECTION 10

GENERAL INFORMATION

Reference Abbreviations	10-2
Important Considerations	10-3
Floor Plan	10-4
Certification Labels	10-9
Towing Guidelines	10-10
Vehicle Weight Distribution	10-10
Gross Combined Weight Rating	10-11
Weight and Towing	10-13
Recommended Tire Pressures	10-13

REFERENCE ABBREVIATIONS

MANUFACTURE/CONVERSION DATE

The date on which the coach portion of your motorhome was built.

GROSS VEHICLE WEIGHT RATING (GVWR)

The maximum permissible weight of this fully loaded motorhome.

SLEEPING CAPACITY WEIGHT RATING (SCWR)

The manufacturer's designated number of sleeping positions multiplied by 154 lbs (70 Kgs).

OCCUPANT AND CARGO CARRYING CAPACITY (OCCC)

The value equal to the GVWR minus UVW and full LP Gas weight. In other words, OCCC is the amount of weight in occupants, cargo, water and trailer tongue weight that can be added to the motorhome without exceeding the GVWR.

GROSS COMBINED WEIGHT RATING (GCWR)

The Gross Combined Weights Rating of the motorhome, i.e, combined weight of the Motorhome and any towed vehicle.

DESIGNATED SLEEPING CAPACITY

The manufacturer's designated number of sleeping positions.

GROSS AXLE WEIGHT RATING (GAWR)

The value specified as the load carrying capacity of a single axle system, as measured at the tire-ground interface.

TIRE SPECIFICATION

Recommended tires specification to meet handling, loading and safety requirements. Replacement tires must meet these specifications.

COLD TIRE INFLATION PRESSURE

Inflation pressures recommended (while cold) for the tires originally installed on your motorhome. These tire pressure levels must be maintained to ensure proper handling, safety and fuel economy.

CARGO CARRYING CAPACITY(CCC) [CANADA ONLY]

Equal to GVWR minus the total of the following: UVW, full fresh (potable) water weight (including water heater), full LP-Gas weight and SCWR.

UNLOADED VEHICLE WEIGHT (UVW)

The weight of this motorhome as manufactured at the factory with full fuel, engine oil and coolants.

MASS OF WASTE WATER TANKS

Total weight of the black and grey water tanks when filled to capacity.

VEHICLE IDENTIFICATION NUMBER (VIN)

This 17 digit number identifies the chassis on which the motorhome is built.

TYPE

The National Highway Traffic Safety Association (NHTSA) designated usage classification for your Motorhome. MPV signifies a Multi-purpose vehicle.

IMPORTANT CONSIDERATIONS

1. The height of the motorhome is measured from the ground to the top of the highest standard component and is based on the UVW of a typically equipped motorhome. The actual height may vary depending on chassis, equipment, build variations or tire pressures. It is important that you know the actual height of your motorhome.
2. The load capacity of your motorhome is designated by weight, not by volume, so you cannot necessarily use all available space when loading your motorhome.
3. Tank capacities are based on measurements prior to tank installation. Slight variations may occur due to tank shrinkage or expansion.
4. Actual filled propane tank capacity is 80% of listed capacity due to overfilling prevention device on tank.

FLOOR PLANS

Arriva

V-24 ("VAN")

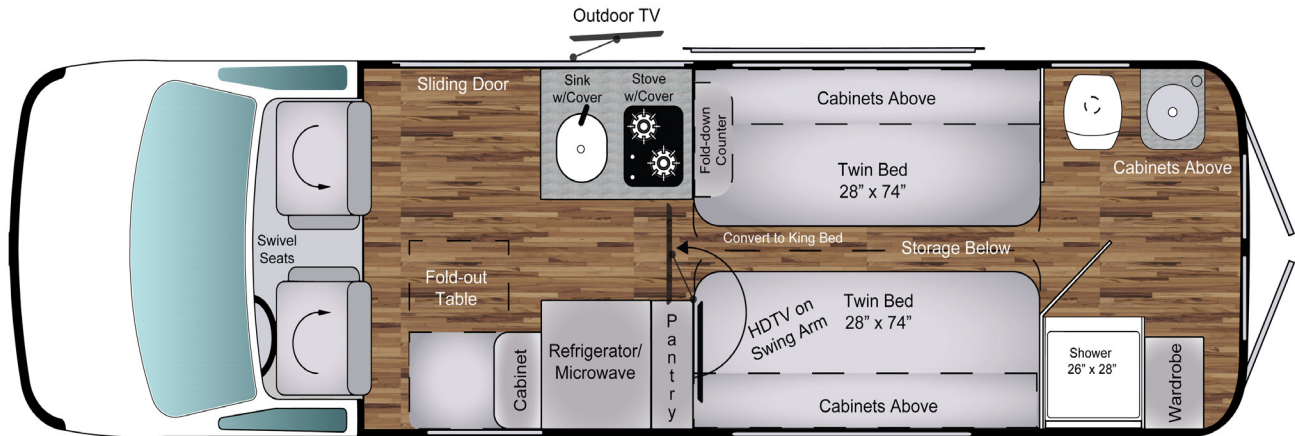

Platinum

220TB ("S")

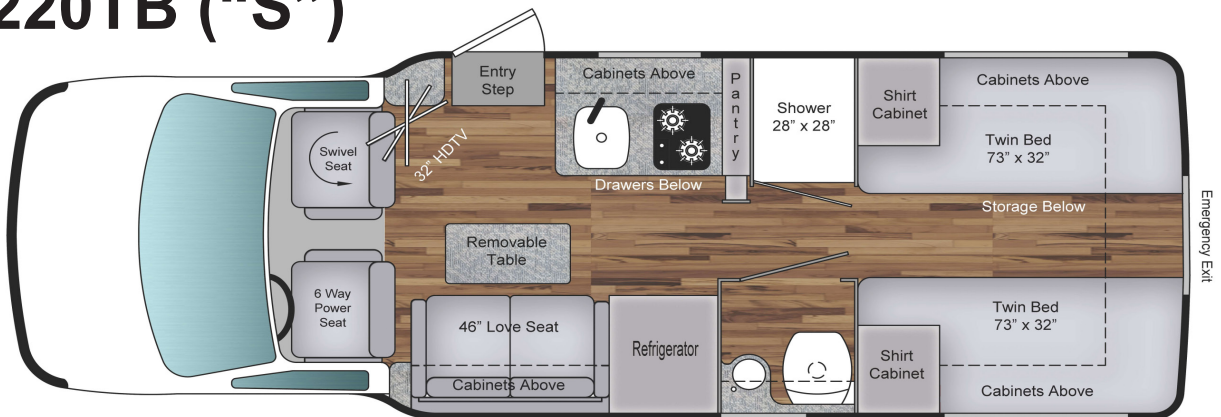

Platinum II

240 Queen ("M")

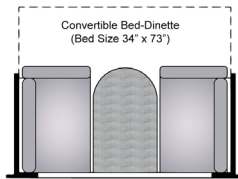
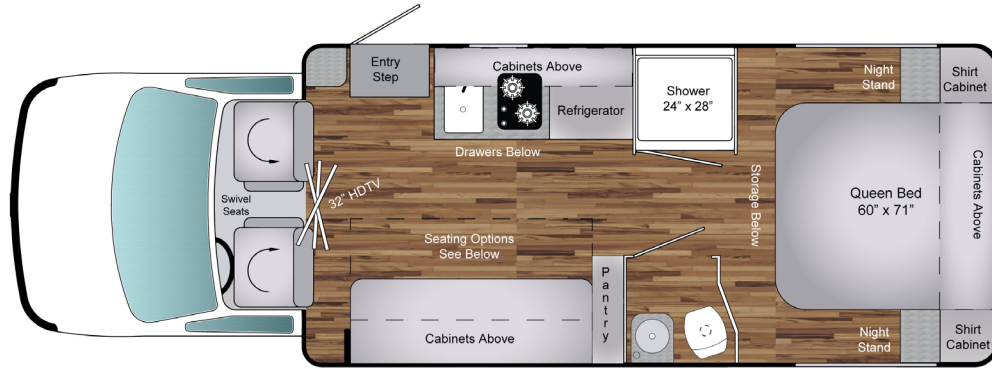

240 DQ
Dinette Queen

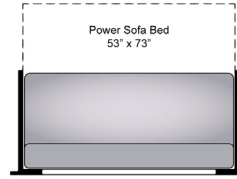

240 SQ
Sofa Queen

240 Rear Twin ("M")

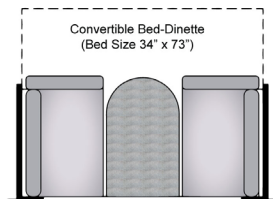
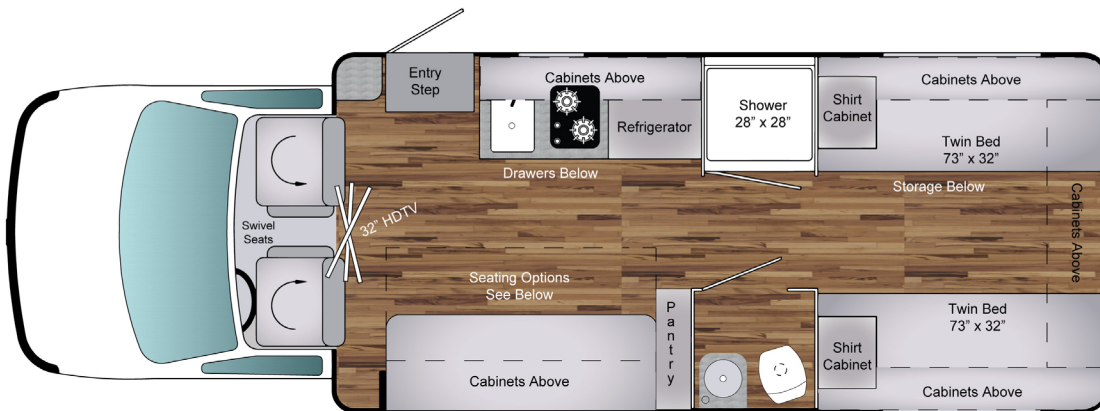

240 DRT
Dinette Rear Twin

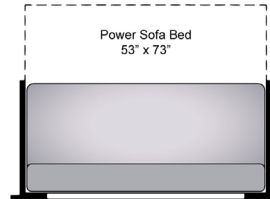

240 SRT
Sofa Rear Twin

241 XL Queen ("M")

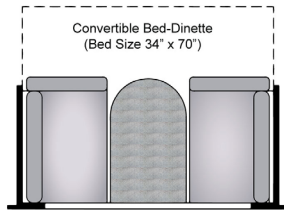
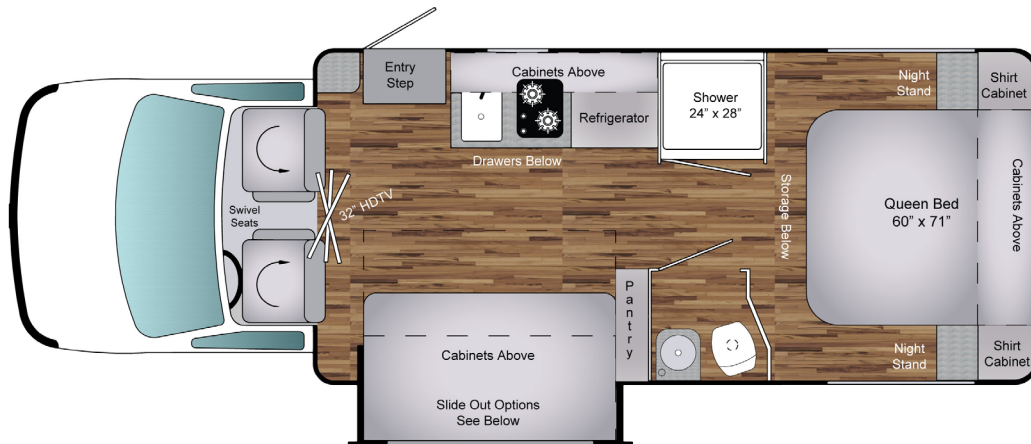

241 XL DQ
Dinette Queen
With Slideout

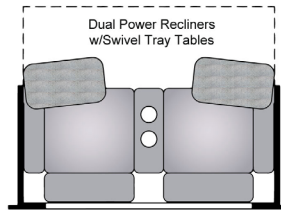

241 XL RQ
Recliner Queen
With Slideout

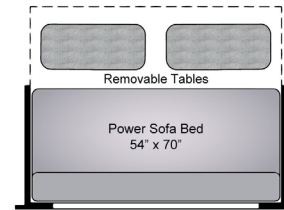

241 XL SQ
Sofa Queen
With Slideout

241 XL Rear Twin ("M")

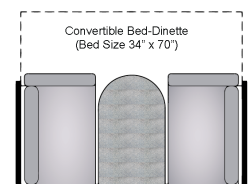
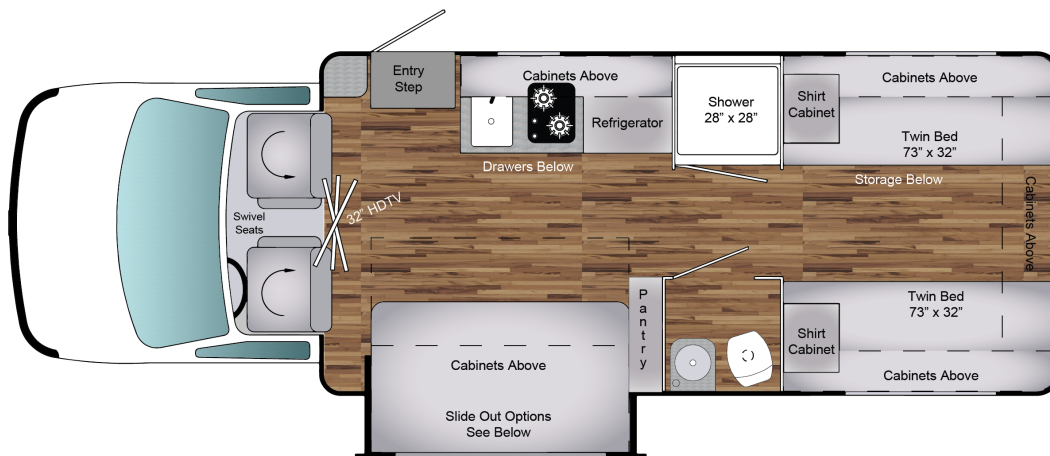

241 XL DRT
Dinette Rear Twin

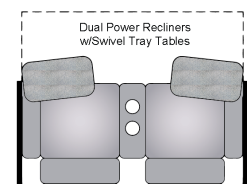

241 XL RRT
Recliner Rear Twin

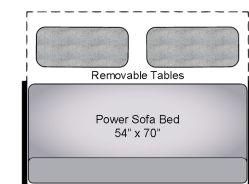

241 XL SRT
Recliner Rear Twin

Platinum III

250 ("T")

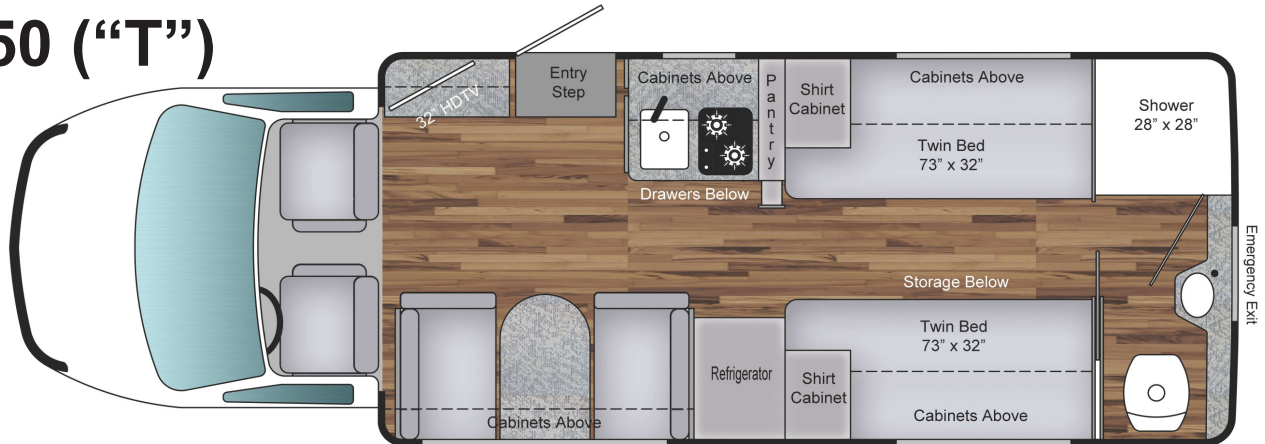

250 DT
Dinette Option



250 ST
Front Sofa Option

Platinum IV

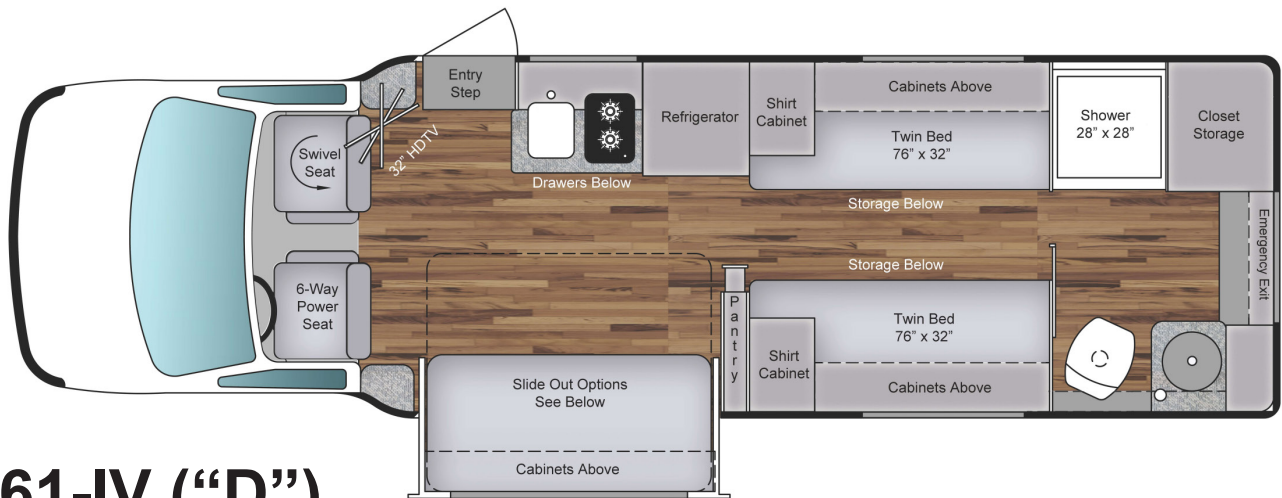

261-IV ("D")

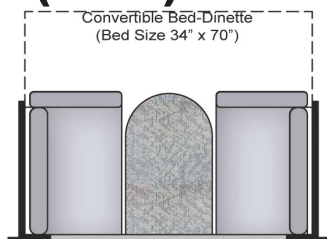

261-IV (FD)
Front Dinette
Single Slideout

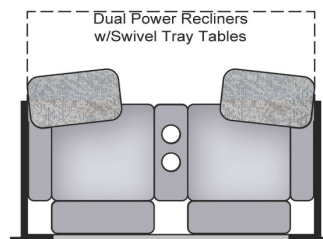

261-IV (FR)
Front Recliner
Single Slideout

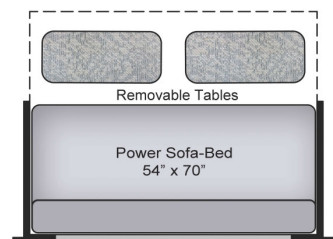

261-IV (FS)
Front Sofa
Single Slideout

271-IV ("K")

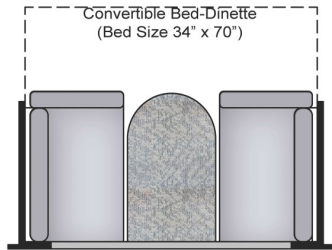
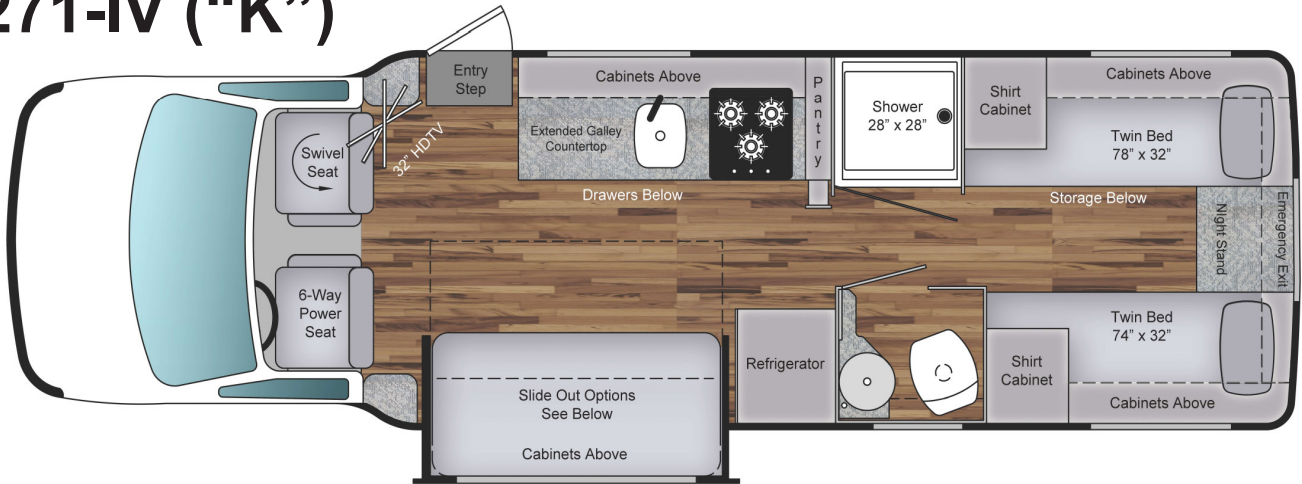

271-IV (FD)
Front Dinette
Single Slideout

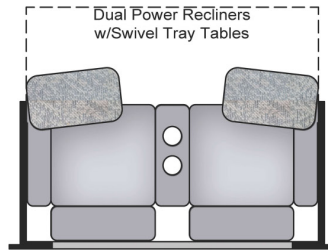

271-IV (FR)
Front Recliner
Single Slideout

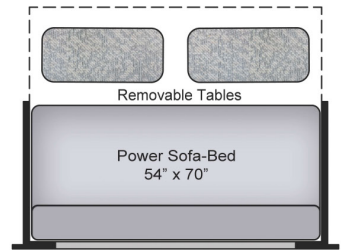

271-IV (FS)
Front Sofa
Single Slideout

272-IV ("G")

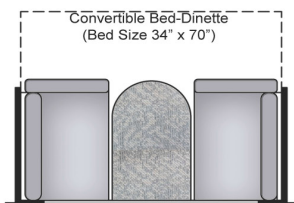
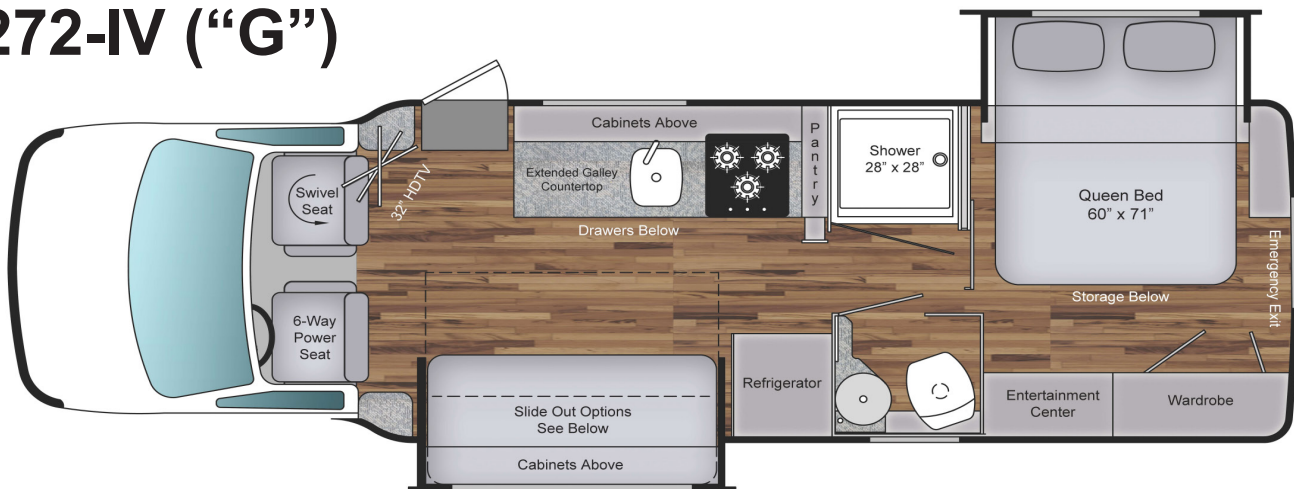

272-IV (FD)
Front Dinette
with Dual Slideouts

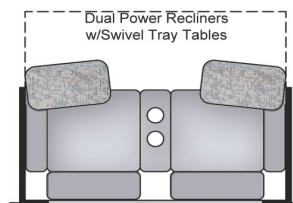

272-IV (FR)
Front Recliner
with Dual Slideouts

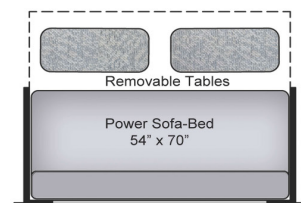

272-IV (FS)
Front Sofa
with Dual Slideouts

CERTIFICATION LABELS

The vehicle certification labels affixed to your motorhome contain identification and other important reference information. Never remove or destroy these labels.

Manufacturer's Vehicle Identification Label

Located inside Driver's Side Door Jamb

MANUFACTURED BY:  Coach House, Inc. VAN MOTOR HOMES		DATE: 05-2019	
INC. VEH. MFG. BY: FORD MOTOR COMPANY		DATE: 04-2019	
THIS VEHICLE CONFORMS TO ALL APPLICABLE FEDERAL MOTOR VEHICLE SAFETY STANDARDS IN EFFECT IN: DATE 4-19	FRONT	REAR	GAWR
	2268 kg (5,000 lb)	4355 kg (9,600 lb)	TIRES
	LT225/75R16E	LT225/75R16E	RIMS
	16x6.0k	16x6.0k	PSI COLD SINGLE
GVWR 6577 kg	520kpa (75) (14,500 lb)	550 kpa (80)	
VEHICLE I.D. NUMBER: 1FDXE4FSXKDC38512	G0226		MODEL NUMBER
COACH HOUSE I.D.: KBC3480E19G226FD2	TYPE: MULTIPURPOSE PASSENGER VEHICLE		

SAMPLE!

TOWING GUIDELINES

To determine the towing capability of your vehicle, first refer to the chassis manufacturer's Owners Manual and/or manufacturers literature that covers your vehicle. Information on your vehicle you need to know is the GROSS COMBINATION WEIGHT RATING (**GCWR**), maximum trailer weight, maximum tongue weight, and the weight of your vehicle fully loaded.

After determining the above information, you can calculate the maximum size trailer you can tow by subtracting your loaded vehicle weight from the GCWR and compare the answer with the maximum trailer weight for your vehicle. Whichever figure is SMALLER will determine the maximum towing capacity (Loaded Trailer Weight) for your vehicle.

It is important to make sure that the tongue weight for your loaded trailer does not exceed the chassis manufacturers rating. Also check the capacity of the hitch installed to make sure you have not exceeded its rating.

VEHICLE WEIGHT DISTRIBUTION

To properly load your vehicle, first determine its empty weight axle by axle and compare this with the GROSS AXLE WEIGHT RATING (**GAWR**), which can be found on the FMVSS sticker located on the driver's door column.

Try to load your vehicle in a manner that proportionally loads the axles according to their available loading capacity. Make sure that your total weight does not exceed the GROSS VEHICLE WEIGHT RATING (**GVWR**) for your vehicle. Be aware that the total of the axle ratings (GAWR) can add up to more than the GVWR. Side to side weight distribution should be considered when loading your vehicle and adjustments made as deemed suitable.

It is recommended that you weigh your vehicle axle by axle when fully loaded especially if the load is close to the OCCUPANT & CARGO CARRYING CAPACITY (OCCC) indicated on the Motorhome Weight Information label for your vehicle. Ensure that none of the stipulated weight capacities have been exceeded. After weighing, make any load adjustments necessary to insure proper vehicle handling and performance.

TOWING AND COMBINED WEIGHT

The GROSS COMBINED WEIGHT RATING (**GCWR**) is defined as the maximum permissible gross weight of the vehicle and trailer. See the following page for information about towing.



Mercedes-Benz

Arriva

<u>Gross Vehicle Weight Rating</u>	G.V.W.R.	11,030 lbs.
<u>Gross Axle Weight Rating (Front)</u>	F.A.W.R.	4,410 lbs.
<u>Gross Axle Weight Rating (Rear)</u>	R.A.W.R.	7,720 lbs.
<u>Gross Combined Weight Rating</u>	G.C.W.R.	15,250 lbs.

Platinum II

<u>Gross Vehicle Weight Rating</u>	G.V.W.R.	11,030 lbs.
<u>Gross Axle Weight Rating (Front)</u>	F.A.W.R.	4,410 lbs.
<u>Gross Axle Weight Rating (Rear)</u>	R.A.W.R.	7,720 lbs.
<u>Gross Combined Weight Rating</u>	G.C.W.R.	15,250 lbs.



Platinum 220

<u>Gross Vehicle Weight Rating</u>	G.V.W.R.	14,500 lbs.
<u>Gross Axle Weight Rating (Front)</u>	F.A.W.R.	5,000 lbs.
<u>Gross Axle Weight Rating (Rear)</u>	R.A.W.R.	9,600 lbs.
<u>Gross Combined Weight Rating</u>	G.C.W.R.	22,000 lbs.

Platinum III 250

<u>Gross Vehicle Weight Rating</u>	G.V.W.R.	10,360 lbs.
<u>Gross Axle Weight Rating (Front)</u>	F.A.W.R.	4,130 lbs.
<u>Gross Axle Weight Rating (Rear)</u>	R.A.W.R.	7,275 lbs.
<u>Gross Combined Weight Rating</u>	G.C.W.R.	13,500 lbs.

Platinum IV 261, 271, 272

<u>Gross Vehicle Weight Rating</u>	G.V.W.R.	14,500 lbs.
<u>Gross Axle Weight Rating (Front)</u>	F.A.W.R.	5,000 lbs.
<u>Gross Axle Weight Rating (Rear)</u>	R.A.W.R.	9,600 lbs.
<u>Gross Combined Weight Rating</u>	G.C.W.R.	22,000 lbs.



Total vehicle load must NOT exceed the maximum GVWR/GAWR/GCWR of the chassis. Brake Failure and/or stopping distance could be affected.

WEIGHT AND TOWING

Labels similar to the samples shown below have been placed on the inside of the passenger side door with weight information for your vehicle. If “CALC” appears after the UVW part of the label, this indicates that the UNLOADED VEHICLE WEIGHT has been calculated by using typical completed model actual weights and making adjustments for certain options.

MOTOR HOME OCCUPANT AND CARGO CARRYING CAPACITY VIN: XXXXXXXXXXXXXXXX
 THE COMBINED WEIGHT OF OCCUPANTS AND CARGO SHOULD NEVER EXCEED
 XXXX kg OR XXXX lbs..
 SAFETY BELT EQUIPPED SEATING CAPACITY: 2
CAUTION:
 A FULL LOAD OF WATER EQUALS XXX kg OR XXX lbs.. OF CARGO @ 1kg/L (8.3 lb/gal)
 AND THE TONGUE WEIGHT OF A TOWED TRAILER COUNTS AS CARGO

CAUTION:
 LOAD CARRYING CAPACITY REDUCED
 MODIFICATIONS TO THIS VEHICLE HAVE REDUCED THE ORIGINAL LOAD CARRYING CAPACITY BY
 _____ kg OR _____ lbs..

RECOMMENDED TIRE PRESSURES

Maintaining the correct air pressure in your tires is vital to the smooth operation and safety of your vehicle. Please refer to the chart below for the recommended air pressure in the front and rear tires.

Look for tire pressure label on driver’s side door jamb.

<u>MODEL</u>	<u>FRONT (PSI)</u>	<u>REAR (PSI)</u>
220	75	80
240	61	61
250	67	62
261, 271, 272	75	80
ARRIVA	61	61